

OPERATION MANUAL



WHITEMAN
MODEL STXDF
HYDRAULIC RIDE-ON TROWEL
(FORD 2.5L DUAL FUEL GAS/PROPANE ENGINE)

Revision #4 (10/12/21)

To find the latest revision of this publication or
associated parts manual, visit our website at:
www.multiquip.com



THIS MANUAL MUST ACCOMPANY THE EQUIPMENT AT ALL TIMES.

PN: 13415

PROPOSITION 65 WARNING



SILICOSIS/RESPIRATORY WARNINGS

! WARNING



SILICOSIS WARNING

Grinding/cutting/drilling of masonry, concrete, metal and other materials with silica in their composition may give off dust or mists containing crystalline silica. Silica is a basic component of sand, quartz, brick clay, granite and numerous other minerals and rocks. Repeated and/or substantial inhalation of airborne crystalline silica can cause serious or fatal respiratory diseases, including silicosis. In addition, California and some other authorities have listed respirable crystalline silica as a substance known to cause cancer. When cutting such materials, always follow the respiratory precautions mentioned above.

! WARNING



RESPIRATORY HAZARDS

Grinding/cutting/drilling of masonry, concrete, metal and other materials can generate dust, mists and fumes containing chemicals known to cause serious or fatal injury or illness, such as respiratory disease, cancer, birth defects or other reproductive harm. If you are unfamiliar with the risks associated with the particular process and/or material being cut or the composition of the tool being used, review the material safety data sheet and/or consult your employer, the material manufacturer/supplier, governmental agencies such as OSHA and NIOSH and other sources on hazardous materials. California and some other authorities, for instance, have published lists of substances known to cause cancer, reproductive toxicity, or other harmful effects.

Control dust, mist and fumes at the source where possible. In this regard use good work practices and follow the recommendations of the manufacturers or suppliers, OSHA/NIOSH, and occupational and trade associations. Water should be used for dust suppression when wet cutting is feasible. When the hazards from inhalation of dust, mists and fumes cannot be eliminated, the operator and any bystanders should always wear a respirator approved by NIOSH/MSHA for the materials being used.

STXDF Ride-On Trowel

Proposition 65 Warning	2
Silicosis/Respiratory Warnings	3
Table of Contents	4
Training Checklist	5
Daily Pre-Operation Checklist	6
Safety Information	7–13
Lifting and Transporting	14–18
Specifications	19
Dimensions	20
General Information	21
Components (Trowel)	22–25
Components (Engine)	26–27
Components (Control Panel)	28
Setup	29
Inspection	30–33
Operation	34–40
Maintenance	41–59
Troubleshooting	60–73
Electrical Wiring Diagram	74
Fuse and Relay Locator	75
Hydraulic Component Locator	76
Hydraulic System Diagram	77

TRAINING CHECKLIST

Training Checklist			
No.	Description	OK?	Date
1	Read operation manual completely		
2	Machine layout, location of components, checking of engine and hydraulic oil levels		
3	Fuel system, refueling procedure		
4	Operation of spray and lights		
5	Operation of controls (machine not running)		
6	Safety controls, safety stop switch operation		
7	Emergency stop procedures		
8	Startup of machine		
9	Maintaining a hover		
10	Maneuvering		
11	Pitching		
12	Matching blade pitch. Smart Pitch™		
13	Concrete finishing techniques		
14	Shutdown of machine		
15	Lifting of machine (lift loops)		

DAILY PRE-OPERATION CHECKLIST

Daily Pre-Operation Checklist		✓	✓	✓	✓	✓	✓
1	Engine oil level						
2	Hydraulic oil level						
3	Radiator coolant level						
4	Condition of blades						
5	Blade pitch operation						
6	Safety stop switch operation						

SAFETY INFORMATION

DO NOT operate or service the equipment before reading the entire manual. Safety precautions should be followed at all times when operating this equipment. Failure to read and understand the safety messages and operating instructions could result in injury to yourself and others.



SAFETY MESSAGES

The four safety messages shown below will inform you about potential hazards that could injure you or others. The safety messages specifically address the level of exposure to the operator and are preceded by one of four words: **DANGER, WARNING, CAUTION** or **NOTICE**.

SAFETY SYMBOLS

 **DANGER**

Indicates a hazardous situation which, if not avoided, **WILL** result in **DEATH** or **SERIOUS INJURY**.

 **WARNING**

Indicates a hazardous situation which, if not avoided, **COULD** result in **DEATH** or **SERIOUS INJURY**.





 **CAUTION**

Indicates a hazardous situation which, if not avoided, **COULD** result in **MINOR** or **MODERATE INJURY**.

NOTICE

Addresses practices not related to personal injury.

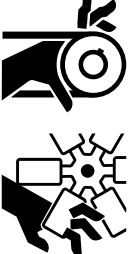
Potential hazards associated with the operation of this equipment will be referenced with hazard symbols which may appear throughout this manual in conjunction with safety messages.





Symbol	Safety Hazard
	Lethal exhaust gas hazards
	Explosive fuel hazards
	Burn hazards
	Rotating parts hazards
	Pressurized fluid hazards
	Hydraulic fluid hazards

SAFETY INFORMATION

SAFETY DECALS

Decals associated with the safe operation of this equipment are defined below.

DECAL	DEFINITION
	<p>DANGER Explosion Hazard Hot steam or coolant may escape when radiator cap is removed, causing severe burns. Allow radiator to cool before removing cap.</p>
	<p>DANGER Guard Hazard DO NOT operate equipment with guards removed. Serious bodily injury could result.</p>
	<p>DANGER Rotating Blade Hazard Keep hands, fingers, and feet clear of engine fan blades and guard rings. Moving parts can cut. DO NOT remove guards. Stop engine before servicing.</p>
	<p>WARNING Cancer and Reproductive Harm This equipment may contain or produce chemicals and substances known to cause cancer, birth defects and other reproductive harm. ALWAYS work in a well-ventilated area and ALWAYS wear approved safety equipment.</p>
	<p>WARNING Lifting/Crush Hazard NEVER allow any person to stand underneath the trowel while lifting. DO NOT lift trowel with pans attached. ALWAYS make sure handle is securely attached.</p>
	<p>CAUTION Burn Hazard HOT PARTS can burn skin. DO NOT touch hot parts. Allow machine sufficient amount of time to cool before performing maintenance.</p>
	<p>NOTICE Protective Clothing ALWAYS wear appropriate clothing when operating the trowel.</p>
	<p>WARNING Fire, Smoking, Explosion, Inhalation Hazard DO NOT smoke or light matches near this equipment. This equipment contains highly flammable fuel. DO NOT use this equipment in an enclosed area.</p>

DECAL	DEFINITION
	<p>CAUTION Burn Hazard HOT PARTS can burn skin. DO NOT touch hot parts. Allow machine sufficient amount of time to cool before performing maintenance.</p>
	<p>NOTICE Lifting Location Attach a suitable lifting device here to lift the unit.</p>
	<p>NOTICE Tie-Down Location ALWAYS tie-down equipment with rope during transport.</p>
	<p>NOISE LEVEL Indicates value of the sound power of the equipment measured at operator's seat.</p>
	<p>UNLEADED GASOLINE The engine used in this equipment runs on unleaded gasoline.</p>

SAFETY INFORMATION

GENERAL SAFETY

CAUTION

- **NEVER** operate this equipment without proper protective clothing, shatterproof glasses, respiratory protection, hearing protection, steel-toed boots and other protective devices required by the job or city and state regulations.



- Avoid wearing jewelry or loose fitting clothes that may snag on the controls or moving parts as this can cause serious injury.

- **NEVER** operate this equipment when on medication or when not feeling well due to fatigue or illness.



- **NEVER** operate this equipment under the influence of drugs or alcohol.



- **ALWAYS** clear the work area of any debris, tools, etc. that would constitute a hazard while the equipment is in operation.

- No one other than the operator is to be in the working area when the equipment is in operation.

- **DO NOT** use the equipment for any purpose other than its intended purposes or applications.

NOTICE

- This equipment should only be operated by trained and qualified personnel 18 years of age and older.

- Whenever necessary, replace nameplate, operation, and safety decals when they become difficult read.

- Manufacturer does not assume responsibility for any accident due to equipment modifications. Unauthorized equipment modification will void all warranties.

- **NEVER** use accessories or attachments that are not recommended by Multiquip for this equipment. Damage to the equipment and/or injury to the user may result.

- **ALWAYS** know the location of the nearest fire extinguisher.



- **ALWAYS** know the location of the nearest first aid kit.



- **ALWAYS** know the location of the nearest phone or **keep a phone on the job site**. Also, know the phone numbers of the nearest **ambulance, doctor** and **fire department**. This information will be invaluable in the case of an emergency.



TROWEL SAFETY

DANGER

- Engine fuel exhaust gases contain poisonous carbon monoxide. This gas is colorless and odorless, and can cause **death** if inhaled.

- Operate equipment only in areas with adequate ventilation. **NEVER** operate in **confined areas**, or in areas where the free flow of air is restricted.



- **NEVER** operate the equipment in an explosive atmosphere or near combustible materials. An explosion or fire could result causing **severe bodily harm or even death**.



WARNING

- If applicable, **NEVER** use your hand to find hydraulic leaks. Use a piece of wood or cardboard. Hydraulic fluid injected into the skin must be treated by a knowledgeable physician immediately or **severe injury or death** can occur.



- **ALWAYS** keep clear of rotating or moving parts while operating the trowel.



SAFETY INFORMATION

- **NEVER** disconnect any **emergency or safety devices**. These devices are intended for operator safety. Disconnection of these devices can cause **severe injury, bodily harm or even death**. Disconnection of any of these devices will void all warranties.

CAUTION

- **NEVER** allow passengers or riders on the trowel during operation.
- **NEVER** lubricate components or attempt service on a running machine.
- **NEVER** place your feet or hands inside the guard rings while starting or operating this equipment.

NOTICE

- **ALWAYS** keep the machine in proper running condition.
- Fix damage to the machine and replace any broken parts immediately.
- **ALWAYS** store equipment properly when it is not being used. Equipment should be stored in a clean, dry location out of the reach of children and unauthorized personnel.
- A safety manual for operating and maintenance personnel of concrete power trowels produced by the Association of Equipment Manufacturers (AEM) can be obtained for a fee by ordering through their website at www.aem.org.

Order SKU PT-160

ENGINE SAFETY

WARNING

- **DO NOT** place hands or fingers inside the engine compartment when the engine is running.
- **NEVER** operate the engine with heat shields or guards removed.
- Keep fingers, hands, hair and clothing away from all moving parts to prevent injury.



- **DO NOT** remove the radiator cap while the engine is hot. High-pressure boiling water will gush out of the radiator and severely scald any persons in the general area of the trowel.

- **DO NOT** remove the coolant drain plug while the engine is hot. Hot coolant will gush out of the coolant tank and severely scald any persons in the general area of the trowel.



- **DO NOT** remove the engine oil drain plug while the engine is hot. Hot oil will gush out of the oil tank and severely scald any persons in the general area of the trowel.

CAUTION

- **NEVER** touch the hot exhaust manifold, muffler or cylinder. Allow these parts to cool before servicing the equipment.



NOTICE

- **NEVER** run the engine without an air filter or with a dirty air filter. Severe engine damage may occur. Service the air filter frequently to prevent engine malfunction.
- **NEVER** tamper with the factory settings of the engine or engine governor. Damage to the engine or equipment can result if operating in speed ranges above the maximum allowable.



FUEL SAFETY (GASOLINE)

DANGER

- **DO NOT** start the engine near spilled fuel or combustible fluids. Fuel is extremely flammable and its vapors can cause an explosion if ignited.
- **ALWAYS** refuel in a well-ventilated area, away from sparks and open flames.
- **ALWAYS** use extreme caution when working with **flammable** liquids.
- **DO NOT** fill the fuel tank while the engine is running or hot.
- **DO NOT** overfill the tank, since spilled fuel could ignite if it comes into contact with hot engine parts or sparks from the ignition system.

SAFETY INFORMATION

- Store fuel in appropriate containers, in well-ventilated areas and away from sparks and flames.
- **NEVER** use fuel as a cleaning agent.
- **DO NOT** smoke around or near the equipment. Fire or explosion could result from fuel vapors or if fuel is spilled on a hot engine. 

FUEL SAFETY (LPG/PROPANE)

DANGER

- **DO NOT** fill the propane tank within 25 ft. (7.62 m) of buildings and line of adjoining structures that may be a source of ignition.
- Remove all combustible materials including dry grass and leaves within 25 ft. (7.62 m) of LPG dispenser.
- Before filling, visually inspect the propane tank for dents, cracks and excessive corrosion.
- **NEVER** fill the propane tank if it is damaged, corroded, displays leaks at fittings\valves, or contains foreign material.
- **NEVER** fill the propane tank if pressure relief or fill valves are damaged.
- **ALWAYS** fill the propane tank in a well-ventilated area, away from sparks and open flames. Liquid propane gas is odorless and invisible.
- **DO NOT** fill the propane tank while the engine is running or hot.
- **DO NOT** smoke around or near the equipment. Fire or explosion could result from gas vapors. 
- Accumulation of liquid propane gas vapors may result in the development of an oxygen-deficient atmosphere which carries a risk of asphyxiation.
- **NEVER** enter a gas cloud area. This condition produces a oxygen-deficient atmosphere that could be fatal.

CAUTION

- **ALWAYS** use protective gloves when handling the propane tank. Liquid propane gas will cause cold burns if it comes into contact with the skin.



- The eyes and body must be protected when handling all liquid propane gas products. **ALWAYS** wear protective eye safety glasses and clothing.
- Liquid propane gas is heavier than air—an underground or low-level leak might not be detected immediately.

BATTERY SAFETY

DANGER

- **DO NOT** drop the battery. There is a possibility that the battery will explode.
- **DO NOT** expose the battery to open flames, sparks, cigarettes, etc. The battery contains combustible gases and liquids. If these gases and liquids come into contact with a flame or spark, an explosion could occur. 

WARNING

- **ALWAYS** wear safety glasses when handling the battery to avoid eye irritation. The battery contains acids that can cause injury to the eyes and skin. 
- Use well-insulated gloves when picking up the battery.
- **ALWAYS** keep the battery charged. If the battery is not charged, combustible gas will build up.
- **DONOT** charge the battery if frozen. The battery can explode. When frozen, warm the battery to at least 61°F (16°C).
- **ALWAYS** recharge the battery in a well-ventilated environment to avoid the risk of a dangerous concentration of combustible gases.
- If the battery liquid (dilute sulfuric acid) comes into contact with **clothing or skin**, rinse skin or clothing immediately with plenty of water. 
- If the battery liquid (dilute sulfuric acid) comes into contact with **eyes**, rinse eyes immediately with plenty of water and contact the nearest doctor or hospital to seek medical attention.

SAFETY INFORMATION

CAUTION

- **ALWAYS** disconnect the **NEGATIVE** battery terminal before performing service on the equipment.
- **ALWAYS** keep battery cables in good working condition. Repair or replace all worn cables.

TRANSPORTING SAFETY

CAUTION

- **NEVER** allow any person or animal to stand underneath the equipment while lifting.
- Ride-on trowels are very heavy and awkward to move around. Use proper heavy lifting procedures and **DO NOT** attempt to lift the trowel by the guard rings.
- **NEVER** lift the trowel with the operator on the machine.



NOTICE

- Two lifting straps should have a minimum lifting capacity of 2,600 pounds (1,179 kg) and the lifting gear must be capable of lifting at least this amount.
- **NEVER** transport the trowel with float pans attached unless safety catches are used and are specifically cleared for such transport by the manufacturer.
- **NEVER** hoist the trowel more than three feet off the ground with float pans attached.
- Before lifting, make sure that the lift loops are not damaged.
- **ALWAYS** make sure the crane or lifting device has been properly secured to the lift loops of the equipment.
- **ALWAYS** shut down the engine before transporting.
- Use adequate lifting cable (wire or rope) of sufficient strength.
- **DO NOT** lift the machine to unnecessary heights.
- **ALWAYS** tie down equipment during transport by securing the equipment with straps. Inspect the straps to make sure they are not frayed or damaged.

TOWING SAFETY

CAUTION

- Check with your local county or state safety towing regulations, in addition to meeting **Department of Transportation (DOT) Safety Towing Regulations**, before towing your trowel.
- In order to reduce the possibility of an accident while transporting the trowel on public roads, **ALWAYS** make sure the trailer that supports the trowel and the towing vehicle are mechanically sound and in good operating condition.
- **ALWAYS** shut down the engine before towing.
- Make sure the hitch and coupling of the towing vehicle are rated equal to or greater than the trailer “gross vehicle weight rating.”
- **ALWAYS** inspect the hitch and coupling for wear. **NEVER** tow a trailer with defective hitches, couplings, chains, etc.
- Check the tire air pressure on both towing vehicle and trailer. **Manufacturer recommends that trailer tires be inflated to 50 psi cold.** Also check the tire tread wear on both vehicles.
- **ALWAYS** make sure the trailer is equipped with a **safety chain**.
- **ALWAYS** properly attach the trailer’s safety chains to the towing vehicle.
- **ALWAYS** make sure the vehicle and trailer directional, backup, brake, and trailer lights are connected and working properly.
- DOT requirements include the following:
 - Connect and test electric brake operation.
 - Secure portable power cables in cable tray with tie-wraps.
- The maximum speed for highway towing is 55 mph unless posted otherwise. Recommended off-road towing is not to exceed 15 mph or less depending on the type of terrain.
- Avoid sudden stops and starts which can cause skidding or jack-knifing. Smooth, gradual starts and stops will improve towing.



SAFETY INFORMATION

- Avoid sharp turns to prevent rolling.
- The trailer should be adjusted to a level position at all times when towing.
- Raise and lock the trailer wheel stand in the **UP** position when towing.
- Place **chock blocks** underneath wheels to prevent rolling while parked.
- Place support blocks underneath the trailer's bumper to prevent tipping while parked.
- Use the trailer's swivel jack to adjust the trailer height to a level position while parked.

ENVIRONMENTAL SAFETY/DECOMMISSIONING

NOTICE

Decommissioning is a controlled process used to safely retire a piece of equipment that is no longer serviceable. If the equipment poses an unacceptable and unrepairable safety risk due to wear or damage or is no longer cost effective to maintain (beyond life-cycle reliability) and is to be decommissioned (demolition and dismantlement), be sure to follow the rules below.

- **DO NOT** pour waste or oil directly onto the ground, down a drain or into any water source.
- Contact your country's Department of Public Works or recycling agency in your area and arrange for proper disposal of any electrical components, waste or oil associated with this equipment.
- When the life cycle of this equipment is over, remove the battery and bring it to an appropriate facility for lead reclamation. Use safety precautions when handling batteries that contain sulfuric acid.
- When the life cycle of this equipment is over, it is recommended that the trowel frame and all other metal parts be sent to a recycling center.



Metal recycling involves the collection of metal from discarded products and its transformation into raw materials to use in manufacturing a new product.

Recyclers and manufacturers alike promote the process of recycling metal. Using a metal recycling center promotes energy cost savings.

EMISSIONS INFORMATION (GASOLINE)

NOTICE

The engine used in this equipment is a dual fuel engine (gasoline/LPG). The gasoline side of the engine has been designed to reduce harmful levels of carbon monoxide (CO), hydrocarbons (HC) and nitrogen oxides (NOx) contained in gasoline exhaust emissions.

This engine has been certified to meet US EPA evaporative emissions requirements in the installed configuration.

Attempting to modify or make adjustments to the engine emission system by unauthorized personnel without proper training could damage the equipment or create an unsafe condition.

Additionally, modifying the fuel system may adversely affect evaporative emissions, resulting in fines or other penalties.

EMISSIONS INFORMATION (LPG)

NOTICE

The LPG (propane) side of the engine used in this equipment uses components that meet US EPA Phase 3 and CARB Large Spark Ignited (LSI) emission regulations.

Any modifications to the fuel system or any adjustments made to the engine will cause the engine to be in **non-compliance** with emission regulations.

Emission Control Label

The emission control label is an integral part of the emission system and is strictly controlled by regulation(s).

The label must remain with the engine for its entire life.

If a replacement emission label is needed, please contact your authorized engine distributor.

LIFTING AND TRANSPORTING

WORK SAFELY!

WARNING



Failure to comply with these lifting instructions may result in **sling failure** and **severe personal injury or death**.

Only **qualified personnel** with proper training should perform this procedure. Follow all rigging and lifting safety rules when performing this procedure.

LIFTING SAFETY

CAUTION

- **NEVER** allow any person to stand underneath the equipment while lifting.
- Ride-on trowels are very heavy and awkward to move around. Use proper heavy lifting procedures and **DO NOT** attempt to lift the trowel by the guard rings.
- **NEVER** lift the trowel with the operator on the machine.

NOTICE

- **NEVER** hoist the trowel more than three feet off of the ground with float pans attached.
- Before lifting, make sure that the lift loops are not damaged.
- **ALWAYS** make sure any lifting device has been properly secured to the lift loops of the trowel.
- **DO NOT** lift the trowel to unnecessary heights.
- **ALWAYS** shut down the engine before transporting.
- Tighten the fuel tank cap securely and close the fuel cock to prevent fuel from spilling.

SLING INSPECTION

Inspect the lifting slings provided with your trowel (Figure 1) **before each use**. If replacement slings are needed, refer to the parts manual included with your trowel for part numbers, and order from your Multiquip parts dealer or importer.

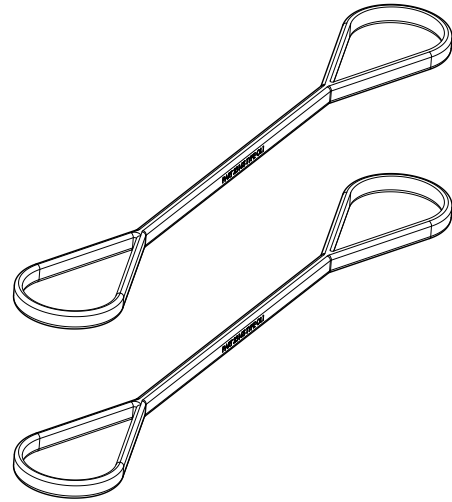
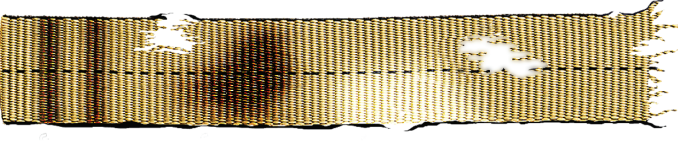

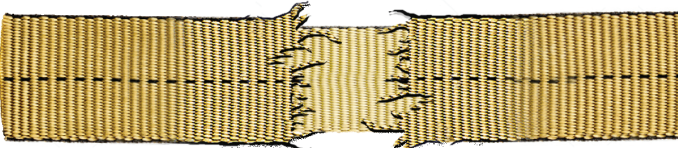
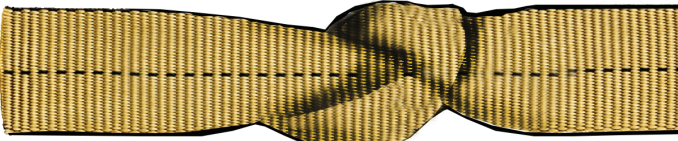

Figure 1. Lifting Slings

LIFTING AND TRANSPORTING

The Occupational Safety and Health Administration (OSHA) Regulation 29 CFR Part 1926.251 (e)(8)—*Removal from service* requires that the slings be inspected prior to each use, and **removed from service immediately** if any of the following conditions are found:

<ul style="list-style-type: none"> ■ Holes, tears, cuts, or snags ■ Embedded particles ■ Abrasive wear that exposes core fibers 	
<ul style="list-style-type: none"> ■ Missing or unreadable Rated Capacity tags ■ Melting, charring, weld spatter, or chemical burns 	
<ul style="list-style-type: none"> ■ Broken or worn stitching that exposes the core fibers 	
<ul style="list-style-type: none"> ■ Knots 	
<ul style="list-style-type: none"> ■ Any other condition which may cause doubt as to the strength of the sling 	

LIFTING AND TRANSPORTING

LIFTING PROCEDURE

The correct lifting slings (Figure 1) have been supplied with your trowel, in accordance to its weight per Occupational Safety and Health Administration (OSHA) Regulation 29 CFR Part 1926.251—*Rigging equipment for material handling*.

WARNING

ALWAYS inspect the lifting slings **before** each use.

NOTICE

MAKE SURE the forklift has adequate lifting capacity to lift the trowel.

The proper sling hitch method for connecting the lifting slings to the ride-on trowel is the **choker hitch**. The rated capacity of the slings for this method is indicated on the sling labels. **DO NOT** use any other type of sling hitch!

1. The trowel can be lifted with the lifting bail raised or lowered. With the lifting bail raised (Figure 2), secure the lifting slings to the lift loops located at the top of the lifting bail.

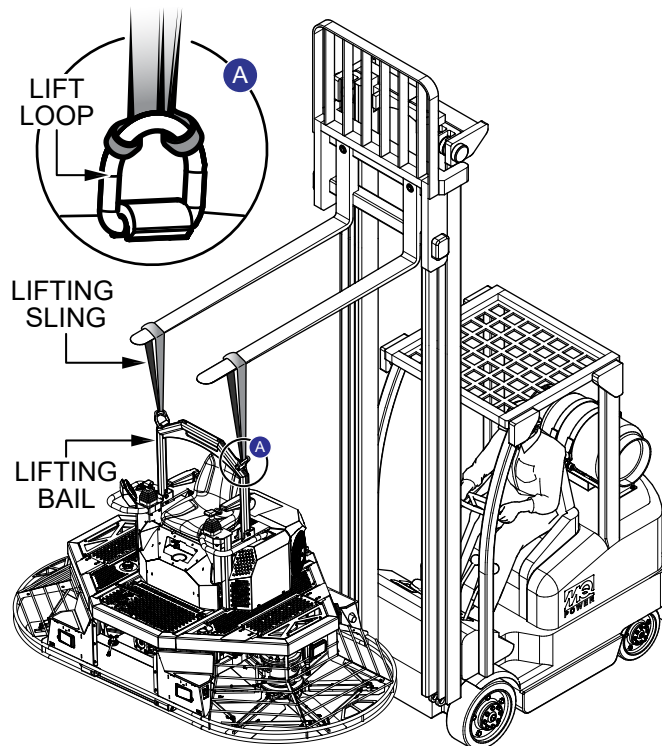

Figure 2. Lifting the Trowel (Lift Loops)

2. With the lifting bail lowered (Figure 3), secure the lifting slings to the lift lugs located at the bottom of the lifting bail.

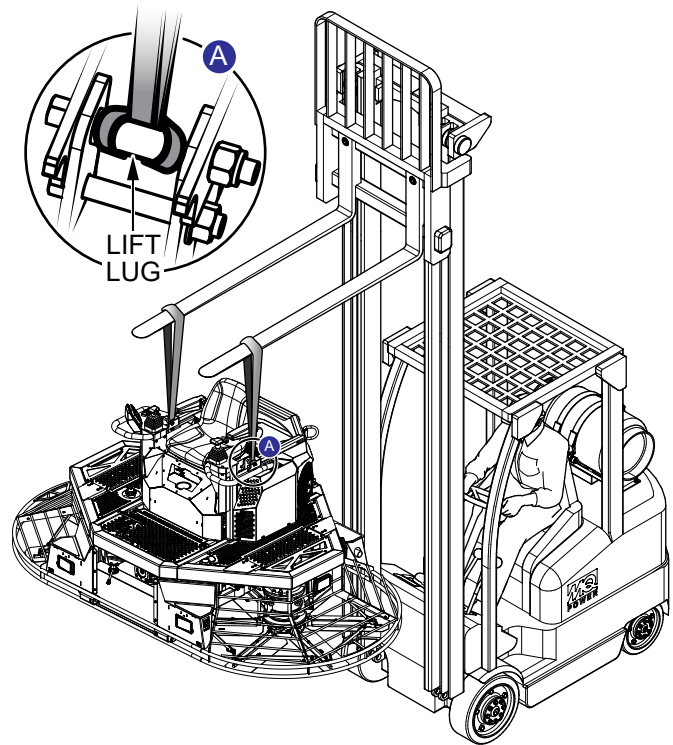

Figure 3. Lifting the Trowel (Lift Lugs)

3. Insert forklift forks through the loops at the ends of the lifting slings. Keep the slings as close to vertical as possible.

LIFTING AND TRANSPORTING

4. If the choke angle (Figure 4) is 120 degrees or less, the lifting strength of the slings must be de-rated as shown in Table 1, in accordance with ASME Standard B30.9.

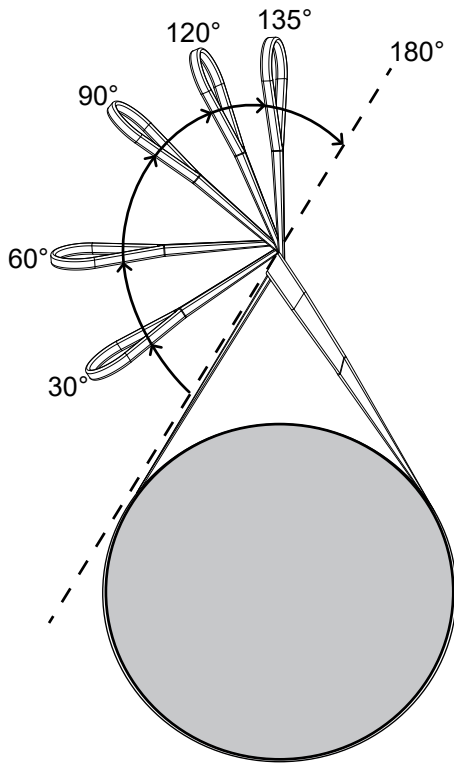

Figure 4. Choke Angle

Table 1. Choker Hitch Sling Capacity	
Choke Angle (°)	Rated Capacity (%)
Over 120	100
90–120	87
60–89	74
30–59	62
0–29	49

Forklift Pocket

Another method for lifting the trowel is with the forklift pocket located at the top of the lifting bail.

1. Make sure the lifting bail is in the upright position (Figure 5).

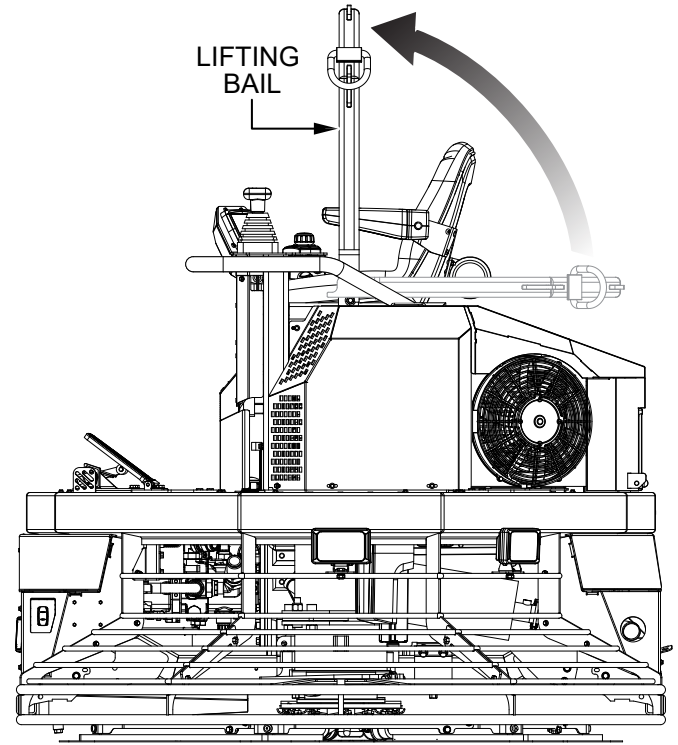

Figure 5. Lifting Bail (Upright)

LIFTING AND TRANSPORTING

2. Insert forklift forks through the forklift pocket (Figure 6) at the top of the lifting bail.

NOTICE
Use tie-downs with flat hooks or U-hooks only.

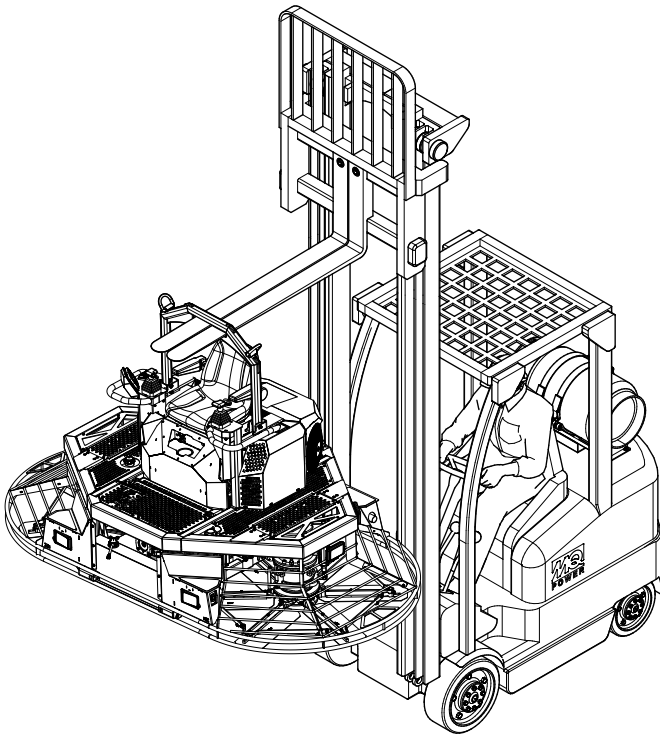

Figure 6. Lifting the Trowel (Forklift Pocket)

TRANSPORTING THE TROWEL

After the trowel has been lifted onto a flatbed truck, do the following:

1. Locate the tie-down symbols (Figure 7) on each side of the trowel.

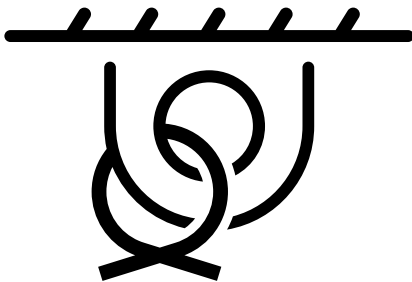

Figure 7. Tie-Down Symbol

2. Attach suitable tie-down straps to the locations marked by the tie-down symbols. Be sure to connect the tie-down strap hooks directly to the trowel as shown in Figure 8. **DO NOT** wrap the tie-downs around the frame as shown in Figure 9.

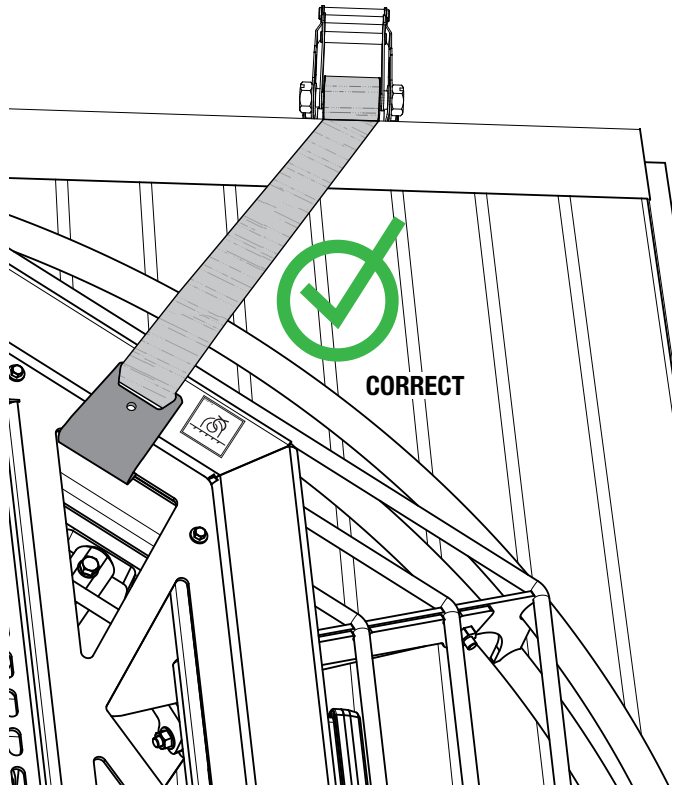

Figure 8. Tie-Down Method (Correct)

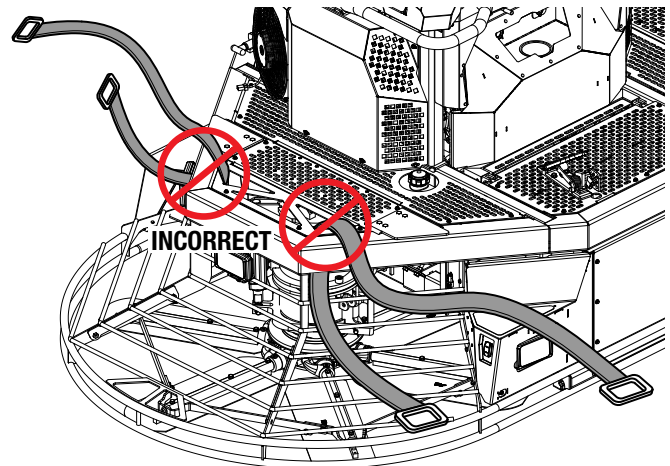

Figure 9. Tie-Down Method (Incorrect)

3. Secure the trowel to a flatbed with the tie-down straps, making sure they are properly tied to prevent movement of the trowel during transport.

SPECIFICATIONS

Table 2. STXDF Trowel Specifications

Operating Weight	2,600 lb. (1,179 kg)
Shipping Weight	TBD
Maximum Rotor Speed	150 rpm
Blades per Rotor	6
Blade Tip Speed	TBD
Path Width	117 in. (2,972 mm)
Hydraulic Oil Capacity	2.01 gallons (7.61 liters)
Hydraulic Oil Type	Parker DuraClean™ ISO 46

Table 3. Engine Specifications

Model	Ford Power Products MSG-425	
Type	2.5-liter, I-4, liquid-cooled, dual OHC	
Number of Cylinders	4	
Displacement	152.5 CID (2,499 cm ³)	
Compression Ratio	9.7:1	
Bore × Stroke	3.5 × 3.93 in. (89 × 100 mm)	
Maximum Output	84 hp (63 kW @ 3,200 rpm)	
Oil Capacity with Filter	6.7 qt. (6.4 liters)	
Oil Type	GF-4, SAE 5W-20	
Coolant Type	50% Motorcraft® Premium Gold engine coolant + 50% distilled water	
Engine Rotation	CCW (viewed from flywheel end)	
Spark Plug Type	AYFS-32Y-R	
Spark Plug Gap	0.049–0.053 in. (1.25–1.35 mm)	
Gasoline	Type	87 or 89 octane unleaded
	Capacity	14.5 gallons (55 liters)
Liquid Propane	Type	HD-5
	Capacity	33.5 lb. (15.2 kg/36.3 liters)

Table 4. STXDF Noise and Vibration Emissions

Guaranteed ISO 11201:2010 Based Sound Pressure Level at Operator Station in dB(A)	96
Guaranteed ISO 3744:2010 Based Sound Power Level in dB(A)	134
Whole Body Vibration per ISO 2631-1:1997 in m/s ² $\Sigma A(8)$	0.01

NOTES:

1. Sound pressure and power levels are “A” weighted measures per ISO 226:2003 (ANSI S1.4-1981). They are measured using operating conditions of the machine which generate the most repeatable but highest values of the sound levels. Under normal circumstances, the sound level will vary depending on the condition of the material being worked upon.
2. The vibration level indicated is the vector sum of the RMS (root mean square) values of amplitudes on each axis, standardized to an 8-hour exposure period, and obtained using operating conditions of the machine that generate the most repeatable but highest values in accordance with the applicable standards for the machine.
3. Per EU Directive 2002/44/EC, the daily exposure action value for whole body vibration is 0.5 m/s² $\Sigma A(8)$. The daily exposure limit value is 1.15 m/s² $\Sigma A(8)$.

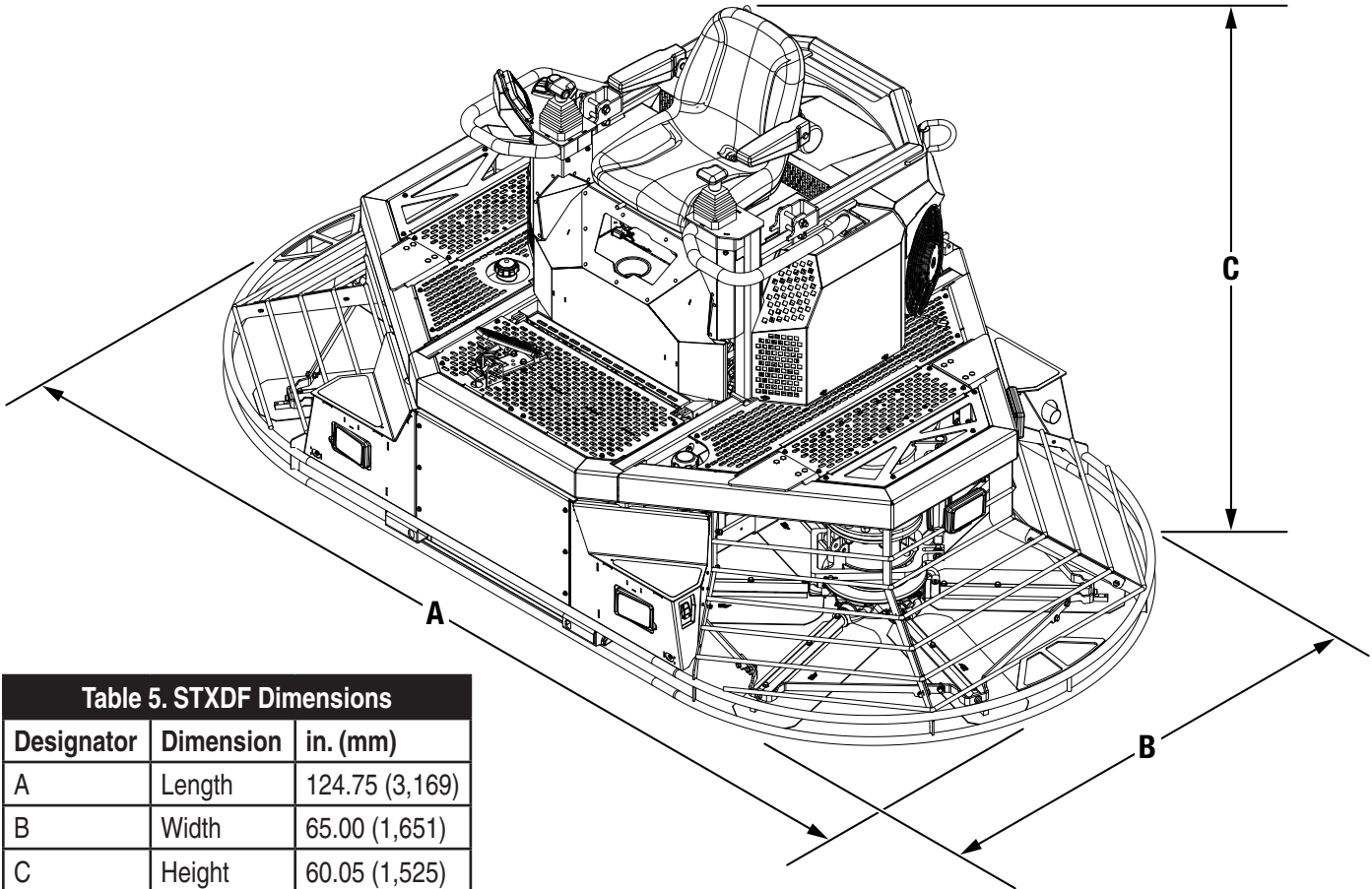

Table 5. STXDF Dimensions		
Designator	Dimension	in. (mm)
A	Length	124.75 (3,169)
B	Width	65.00 (1,651)
C	Height	60.05 (1,525)

Figure 10. STXDF Dimensions

INTENDED USE

Operate the STXDF ride-on trowel, tools, and components in accordance with the manufacturer's instructions. Use of any other tools for stated operation is considered contrary to designated use. The risk of such use lies entirely with the user. The manufacturer cannot be held liable for damages as a result of misuse.

FAMILIARIZATION

The STXDF ride-on power trowel is designed for the floating and finishing of concrete slabs.

Walk around the trowel and take note of the major components—engine, blades, air cleaner, fuel system, fuel shut-off valve, ignition switch, etc. Make sure there is always a proper level of oil in the engine and a proper level of hydraulic oil in the hydraulic oil reservoir.

Read all safety information carefully. Safety instructions will be found throughout this manual and on the machine. Keep all safety information in good, readable condition. Operators should be well trained on the operation and maintenance of the trowel.

Before using your trowel, test it on a flat, watered-down section of finished concrete. This test run will familiarize you with the trowel's controls and will increase your confidence in operating the trowel. You will learn how the trowel handles under actual operating conditions. Refer to the **Operation** section of this manual for more information.

ENGINE

The STXDF is equipped with a Ford MSG-425 engine which operates on either unleaded gasoline or liquid propane gas (LPG). Refer to the engine owner's manual for specific instructions regarding engine operation and maintenance.

BLADES

The blades of the STXDF finish concrete as they are rotated across the surface. Blades are classified as *combination* (10 or 8 inches wide) or *finish* (6 inches wide). The STXDF is equipped with six blades per rotor equally spaced in a radial pattern and attached to a vertical rotating shaft by means of a spider assembly.

OPTIMIZED HYDRAULIC SYSTEM

The STXDF's spider assemblies are driven by two independent radial piston hydraulic motors coupled to a high-efficiency variable displacement hydraulic pump for increased overall system performance.

DIGITAL CONTROLS

The STXDF is equipped with a digital control panel and display that communicates with the trowel Engine Control Unit (ECU) using the SAE J1939 Controller Area Network (CAN) bus protocol.

HYDRAULIC STEERING

Dual palm-grip joystick controls located to the left and right of the operator are provided for steering. The joysticks are linked to three hydraulic steering cylinders located within the frame of the machine.

DUAL FUEL SYSTEM

The STXDF can be equipped with a liquid propane gas (LPG) tank (sold separately—refer to the parts manual included with the trowel for part numbers) which may be used instead of gasoline. Fuel systems can be switched without interrupting operation using the digital control panel.

TRAINING

For proper training, please use the **Training Checklist** form located in the front of this manual. This checklist will provide an outline for an experienced operator to provide training to a new operator.

COMPONENTS (TROWEL)

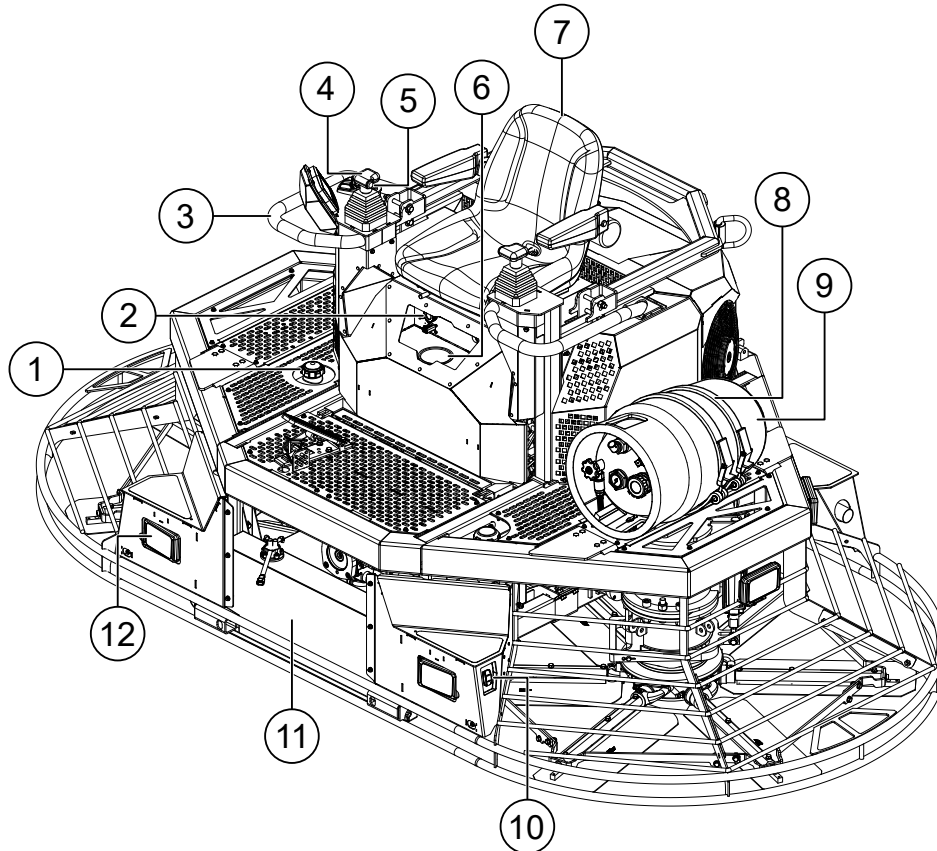

Figure 11. Trowel Components

1. **Retardant Spray Tank** — Remove the filler cap to add retardant to the tank. Holds up to 5 gallons (18.9 liters) of retardant.
2. **Service Port** — Connect the Whiteman Service Tool (WST) here to install and update trowel software and perform adjustments and calibrations.
3. **Grab Bar (Right Side)** — Always use a grab bar to lift yourself onto the trowel.
4. **Steering Control Handle (Right Side)** — Located to the left and right of the operator, these dual palm-grip joysticks are linked to three hydraulic steering cylinders. Refer to the **Operation** section to learn more about steering.
5. **Retardant Spray Control Button (Right Side)** — Located on the right-side steering control handle, this button controls the flow of retardant spray through the right-side nozzle at the front of the trowel.
6. **Cup Holder** — Stainless steel cup holder.
7. **Operator's Seat** — Adjustable operator's seat tilts forward for service access.
8. **Propane Tank Straps** — Straps with latches secure the optional propane tank to the frame.
9. **Propane Tank (Optional)** — Holds up to 33.5 lb. (36.3 liters) of liquid propane gas (LPG). Use HD-5 liquid propane only.
10. **Drive Bypass Switch (Left Side)** — Used for jogging the rotors while lifting the trowel from a concrete pad to prevent surface marring. Can also be used to rotate the blades when installing float pans. Refer to the **Operation** and **Maintenance** sections for more information.
11. **Fuel Tank (Gasoline)** — Holds 14.5 gallons (55 liters) of unleaded gasoline. Use 87 or 89 octane gasoline only.
12. **Light (Front Right)** — One of six 20-watt LED lights that provide illumination for indoor or nighttime finishing.

COMPONENTS (TROWEL)

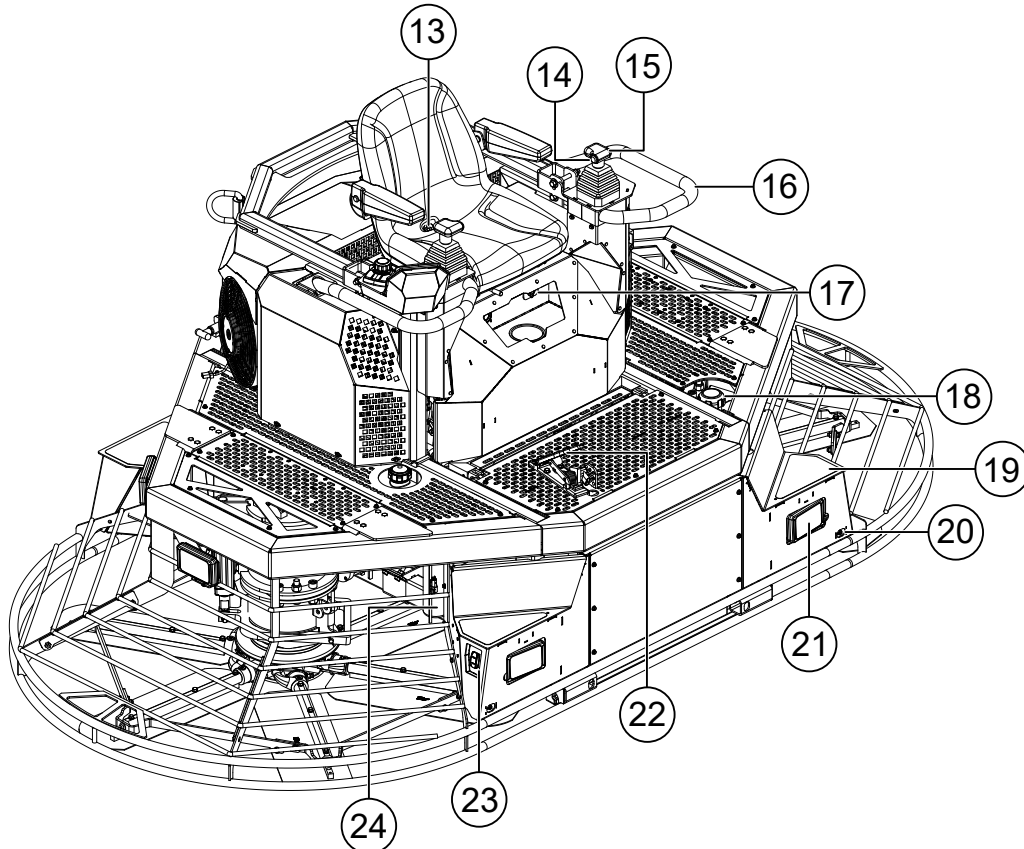

Figure 12. Trowel Components (Cont.)

13. **Seat Switch** — Safety feature stops blade rotation when the operator leaves the seat. The trowel blades will not turn and engine speed will not rise above idle unless the operator is seated.
14. **Retardant Spray Control Button (Left Side)** — Located on the left-side steering control handle, this button controls the flow of retardant spray through the left-side nozzle at the front of the trowel.
15. **Steering Control Handle (Left Side)** — Located to the left and right of the operator, these dual palm-grip joysticks are linked to three hydraulic steering cylinders. Refer to the **Operation** section to learn more about steering.
16. **Grab Bar (Left Side)** — Always use a grab bar to lift yourself onto the trowel.
17. **Dual USB Port** — Dual accessory port for personal electronic devices. Maximum current per port is 2.1 amps.
18. **Fuel Filler Cap** — Remove the red fuel filler cap to add unleaded gasoline to the fuel tank. Use 87 or 89 octane gasoline only.
19. **Step (Front Left)** — Used for mounting and dismounting the trowel.
20. **Retardant Spray Nozzle (Left Side)** — Spray nozzles are actuated by the buttons on the steering control handles and provide uniform coverage of retardant over the slab surface.
21. **Light (Front Left)** — One of six 20-watt LED lights that provide illumination for indoor or nighttime finishing.
22. **Foot Pedal** — Controls rotor speed. Slightly depress the foot pedal to obtain minimal rotor speed. Fully depress the foot pedal to obtain maximum rotor speed.
23. **Drive Bypass Switch (Right Side)** — Used for jogging the rotors while lifting the trowel from a concrete pad to prevent surface marring. Can also be used to rotate the blades when installing float pans. Refer to the **Operation** and **Maintenance** sections for more information.
24. **Hydraulic Filter** — Filters hydraulic fluid as it enters the system. Equipped with 10-micron absolute synthetic filter media.

COMPONENTS (TROWEL)

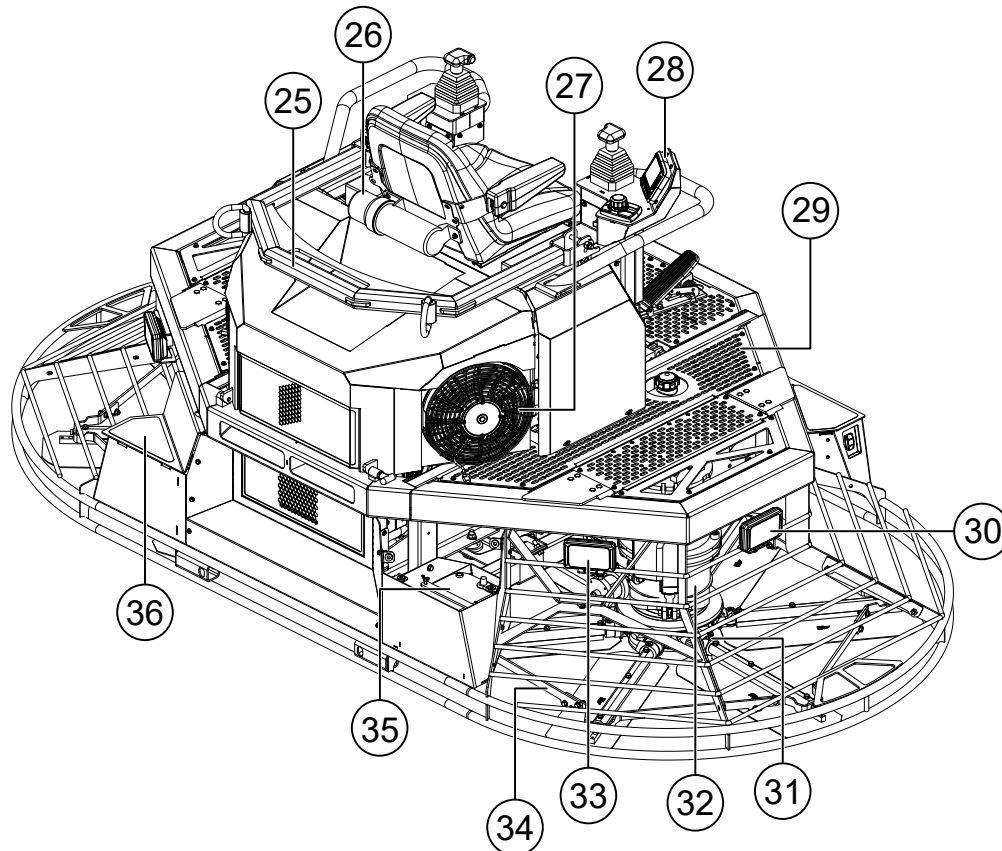

Figure 13. Trowel Components (Cont.)

- 25. **Lifting Bail** — Balanced lifting point for lifting the trowel. Refer to the *Lifting and Transporting* section for more information.
- 26. **Documentation Holder** — Storage for trowel and engine manuals.
- 27. **Heat Exchanger (Right Side)** — Keeps hydraulic oil at the optimum operating temperature.
- 28. **Digital Display** — 3.5-inch LCD color display provides trowel and engine information at a glance. Refer to the *Components (Control Panel)*, *Operation*, and *Troubleshooting* sections for more information.
- 29. **Trowel Platform** — Spacious platform provides easy access to the operator's seat and service areas.
- 30. **Light (Right Side)** — One of six 20-watt LED lights that provide illumination for indoor or nighttime finishing.
- 31. **Spider Assembly (Right Side)** — Each spider assembly contains six trowel arms with 8-inch combination blades equally spaced in a radial pattern.
- 32. **Hydraulic Motor (Right Side)** — This radial piston hydraulic motor rotates the right-side spider assembly.
- 33. **Light (Rear Right)** — One of six 20-watt LED lights that provide illumination for indoor or nighttime finishing.
- 34. **Stabilizer Ring (Right Side)** — New sectional design provides enhanced stability and facilitates maintenance.
- 35. **Battery** — Provides +12VDC to the electrical system. Remove the right rear step to access the battery.
- 36. **Step (Rear Left)** — Used for mounting and dismounting the trowel.

COMPONENTS (TROWEL)

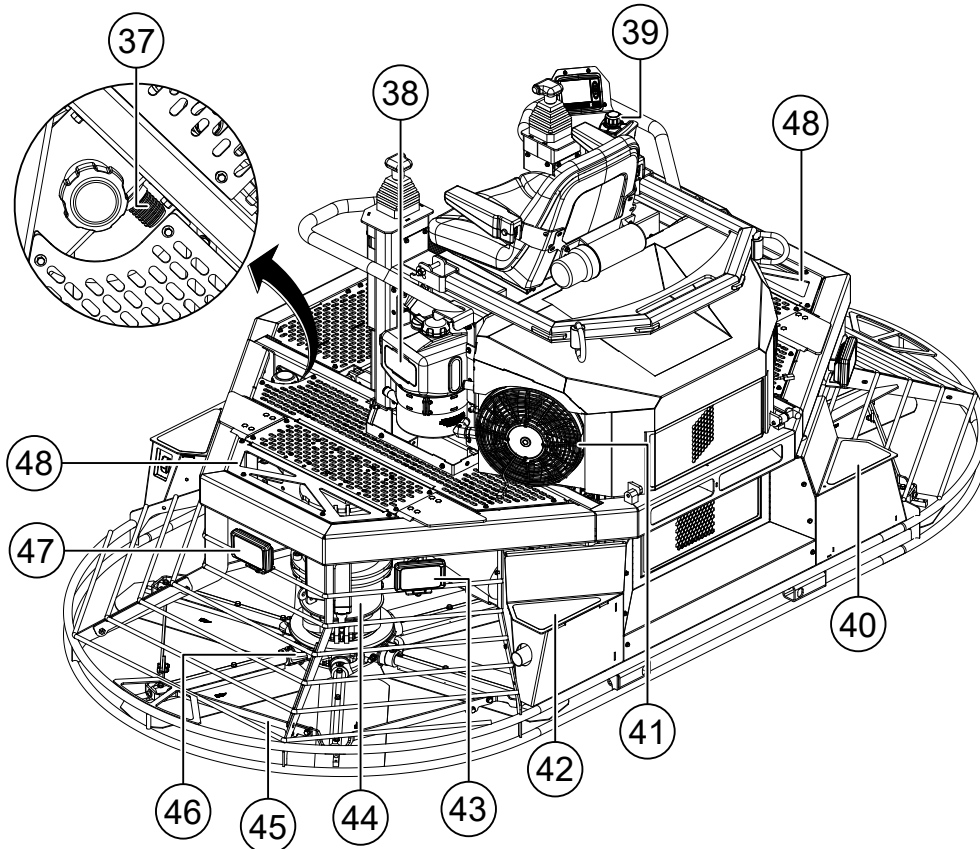

Figure 14. Trowel Components (Cont.)

- 37. **LPG Line Stow** — Connect the LPG line to this fitting when removing the propane tank.
- 38. **Hydraulic Oil Reservoir** — Visually inspect the level of hydraulic oil in the reservoir through the window at the rear of the reservoir. Remove the filler cap to add hydraulic oil. Open **only** when the system is **cool**. Reservoir holds up to 2.0 gallons (7.6 liters) of hydraulic oil. Use Parker DuraClean™ ISO 46 hydraulic oil only.
- 39. **Control Panel** — Includes controls for blade pitch, engine speed, fuel selection, lights, and more. Refer to the **Components (Control Panel)** and **Operation** sections for more information.
- 40. **Step (Rear Right)** — Used for mounting and dismantling the trowel. Remove to access the battery.
- 41. **Heat Exchanger (Left Side)** — Keeps hydraulic oil at the optimum operating temperature.
- 42. **Step (Rear Left)** — Used for mounting and dismantling the trowel.
- 43. **Light (Rear Left)** — One of six 20-watt LED lights that provide illumination for indoor or nighttime finishing.
- 44. **Hydraulic Motor (Left Side)** — This radial piston hydraulic motor rotates the left-side spider assembly.
- 45. **Stabilizer Ring (Left Side)** — New sectional design provides enhanced stability and facilitates maintenance.
- 46. **Spider Assembly (Left Side)** — Each spider assembly contains six trowel arms with 8-inch combination blades equally spaced in a radial pattern.
- 47. **Light (Left Side)** — One of six 20-watt LED lights that provide illumination for indoor or nighttime finishing.
- 48. **Tie-Down Locations** — Secure tie-down straps to these attachment points when transporting the trowel.

COMPONENTS (ENGINE)

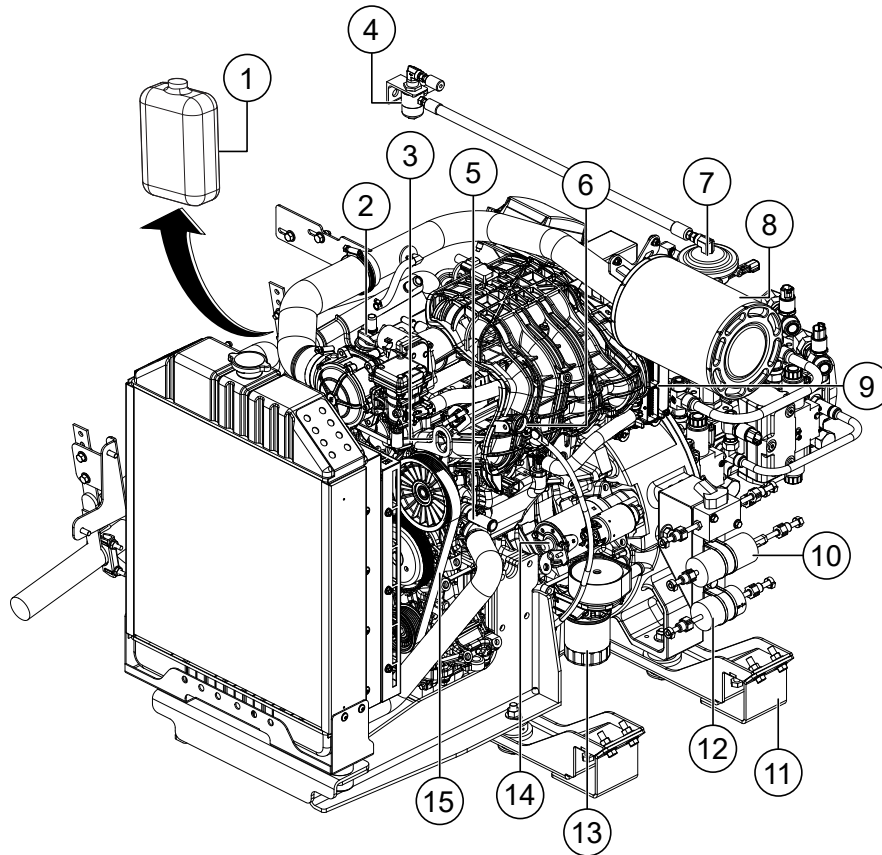

Figure 15. Ford MSG-425 Engine Components

1. **Overflow Bottle** — Supplies coolant to the radiator when the coolant level is low. Fill to the level indicated on the bottle.
2. **Oil Filler Port** — Remove the cap to add fresh oil as specified in Table 3.
3. **Lifting Eye (2)** — Located on either side of the engine. Used when the engine must be lifted for service.
4. **Propane Filter** — Filters LPG contaminants.
5. **Thermostat** — Regulates engine temperature.
6. **Oil Dipstick** — Remove to check the amount and condition of oil in the crankcase.
7. **LPG Shutoff Valve** — Controls the flow of LPG fuel.
8. **Air Cleaner** — Prevents dirt and debris from entering the engine cylinders.
9. **Engine Control Unit (ECU)** — Communicates with engine sensors and actuators to ensure optimal engine performance.
10. **Fuel Pump** — Delivers gasoline fuel to the engine.
11. **Engine Mounting Bracket (2)** — Mounting brackets with rubber isolators secure the engine to the frame.
12. **Fuel Filter** — Filters gasoline fuel contaminants.
13. **Oil Filter** — Filters engine oil contaminants.
14. **Starter** — Starts the engine when the ignition key is rotated to the **START** position.
15. **Drive Belt** — Driven by the engine crankshaft. Drives the coolant pump, alternator, etc.

COMPONENTS (ENGINE)

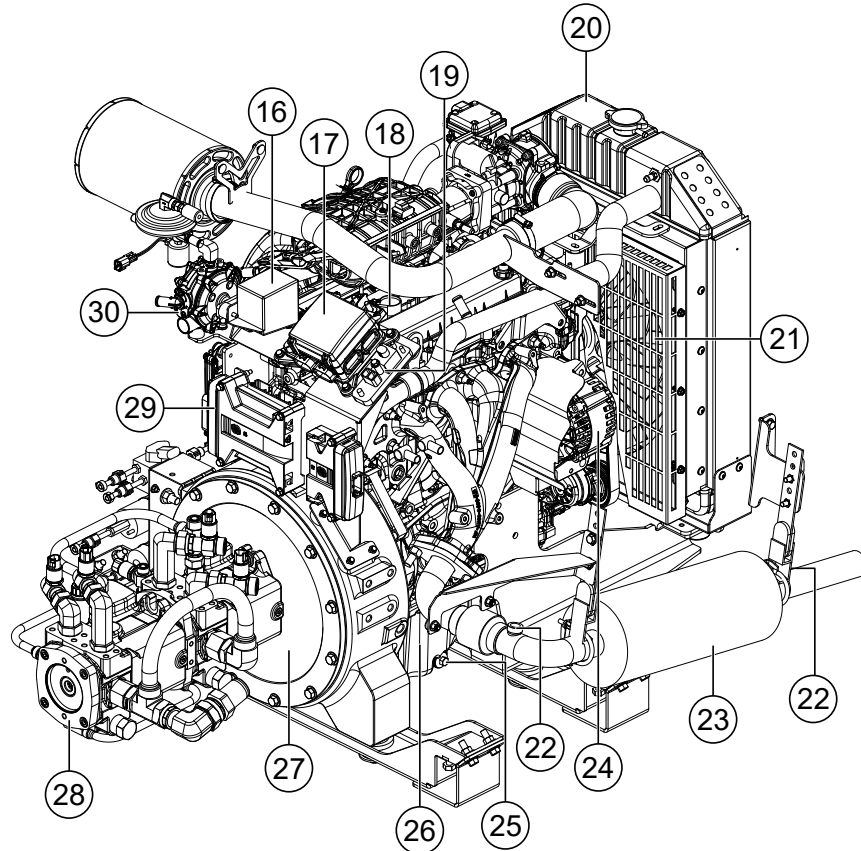

Figure 16. Ford MSG-425 Engine Components (Cont.)

16. **Engine Fuse and Relay Box** — Contains fuses and relays for engine control.
17. **Machine Fuse and Relay Box** — Contains fuses and relays for machine control.
18. **Spark Plug (4)** — Provides spark to the ignition system. Set the spark plug gap to 0.049–0.053 in. (1.25–1.35 mm).
19. **Power Relay Module** — Contains main system fuses.
20. **Radiator** — Holds coolant (water/antifreeze mixture) which keeps the engine at a safe operating temperature. Remove the cap when the engine is cool to add coolant.
21. **Engine Fan** — Draws air through the radiator to cool the engine.
22. **O₂ Sensor** — Monitors oxygen in the exhaust stream and communicates with the ECU to maintain the optimum air/fuel ratio.
23. **Catalytic Converter/Muffler** — Reduces noise and emissions. **NEVER** touch the muffler while the engine is running.
24. **Alternator** — Provides current to the electrical system and charges the battery.
25. **Oil Drain Bolt** — Remove to drain crankcase oil.
26. **Oil Pan** — Holds a maximum of 7 quarts (6.6 liters) of engine oil.
27. **Flywheel** — Prevents fluctuations in engine speed.
28. **Hydraulic Pump** — High-efficiency variable displacement tandem pump drives the motors that turn the blades.
29. **Machine Control Unit (MCU)** — Connects to machine sensors, switches, actuators, fuse box, engine and display to control the machine.
30. **LPG Vapor Regulator** — Converts propane from liquid to gas and delivers it to the engine.

COMPONENTS (CONTROL PANEL)

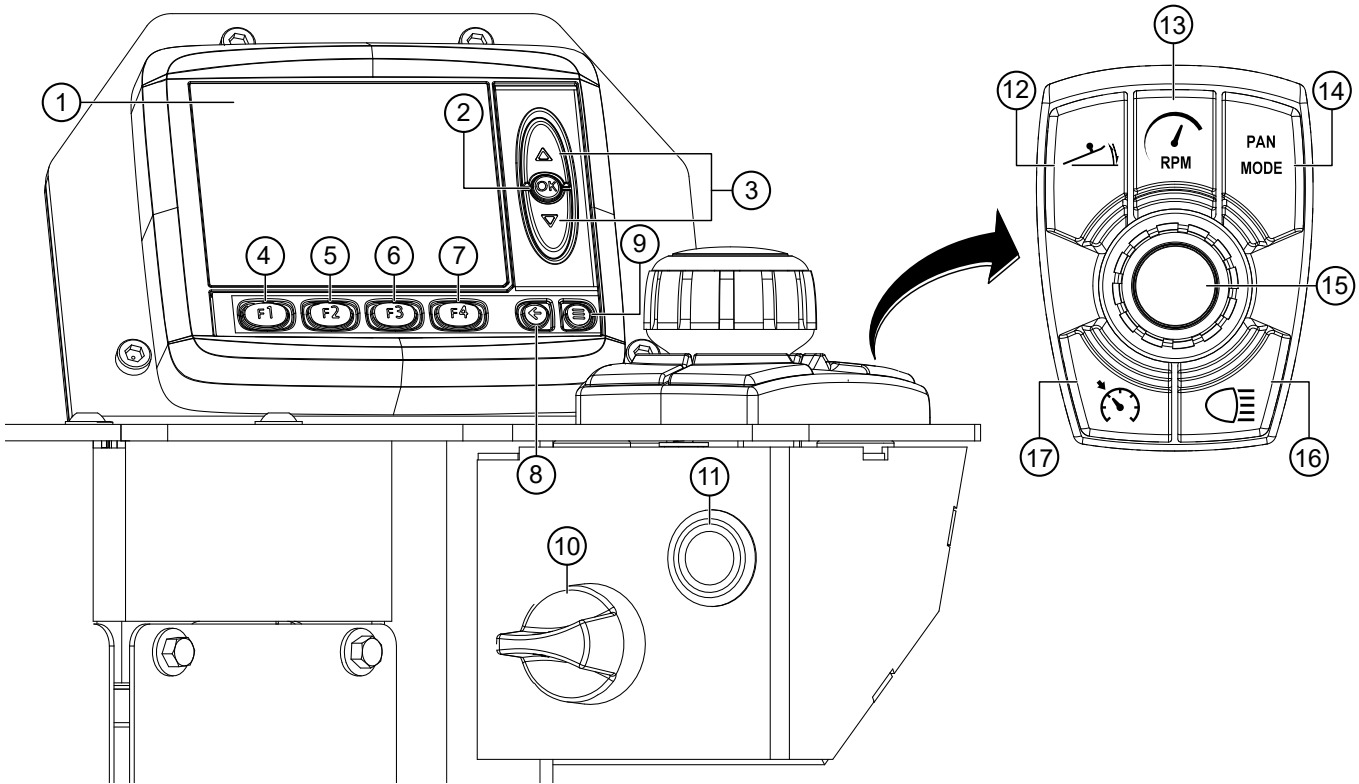

Figure 17. Control Panel

1. **Digital Display** — 3.5-inch LCD color display provides information on blade pitch, rotor speed, fuel selection, fuel level, engine and machine faults, engine speed, and cruise control.
2. **Enter (OK) Button** — Press to save the value or confirm the selection you have made.
3. **Up and Down Arrow Buttons** — Press these buttons to scroll up or down through menu options.
4. **F1 Button** — Press to display fault information.
5. **F2 Button** — Press to display engine information.
6. **F3 Button** — Press to display machine information.
7. **F4 Button** — Press to change units of measurement.
8. **Back (ESC) Button** — Press to return to the previous screen.
9. **Menu Button** — Press to display the menu screen.
10. **Ignition Switch** — Insert the ignition key here and turn clockwise to start the engine.
11. **Fuel Selector Button** — Press to toggle between gasoline and LPG fuel modes.
12. **Blade Pitch Button** — Press to display the blade pitch adjustment screen.
13. **Rotor Speed (RPM) Button** — Press to display the maximum rotor speed adjustment screen.
14. **Panning Mode Button** — Press and hold for 3 seconds to disengage pitch systems for float pan operation.
15. **Control Knob** — The control knob has several functions:
 - Turn the control knob to adjust the currently selected setting (blade pitch, rotor speed, etc.)
 - When on the main screen, press the knob to switch the engine between operating speed and idle.
 - When on the blade pitch screen, press the knob to toggle between right rotor, left rotor, and dual pitch.
16. **Lights Button** — Press to turn trowel lights ON/OFF.
17. **Cruise Control Button** — Press to turn cruise control ON/OFF.

BATTERY

CAUTION

Use all safety precautions specified by the battery manufacturer when handling the battery. See the **Safety Information** section of this manual for details on battery safety.

The trowel is equipped with an AGM battery. The battery may need to be charged for a brief period of time as per the battery manufacturer's instructions. Connect the battery as follows:

1. To access the battery, pull upward on the rear right step (Figure 18) to remove it. Set the step aside.

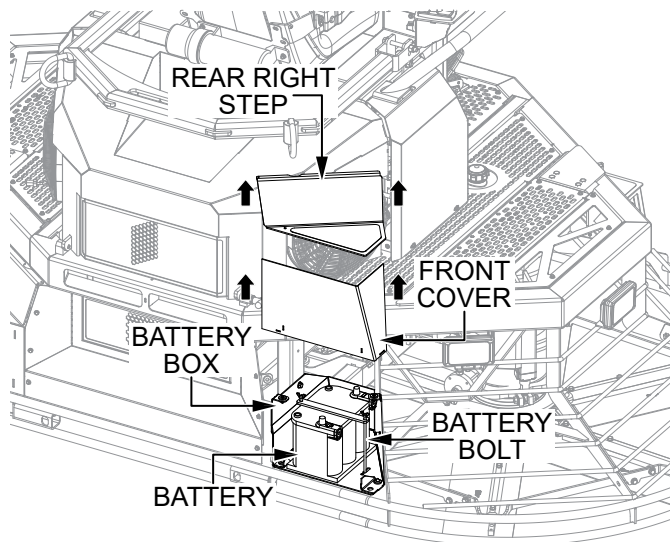

Figure 18. Battery Access

2. Remove the battery box front cover (Figure 18) and set it aside.
3. Make sure the battery is well seated in the battery box and secured with the two battery bolts (Figure 18).

4. Connect the positive (**RED**) battery cable to the positive (+) terminal on the battery, then connect the negative (**BLACK**) battery cable to the negative (-) terminal. See Figure 19.

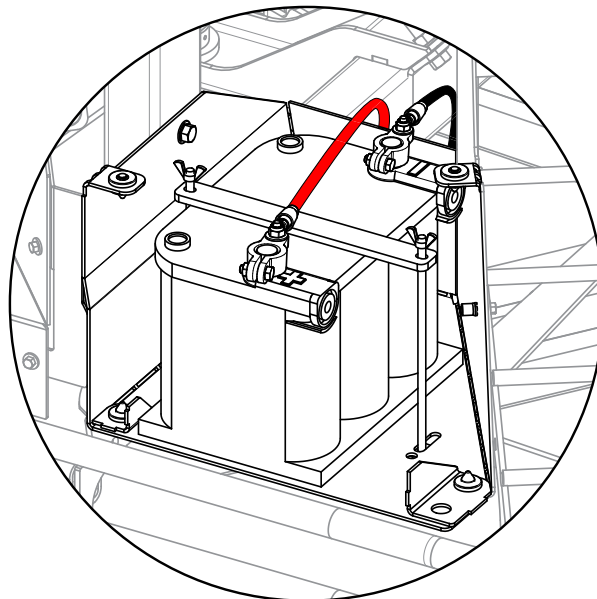

Figure 19. Battery Connection

5. Reinstall the battery box front cover and rear right step.

ENGINE OIL

1. Make sure the trowel is secured on a level surface with the engine stopped.
2. Pull the engine oil dipstick (Figure 20) out of its holder and wipe it with a clean rag.

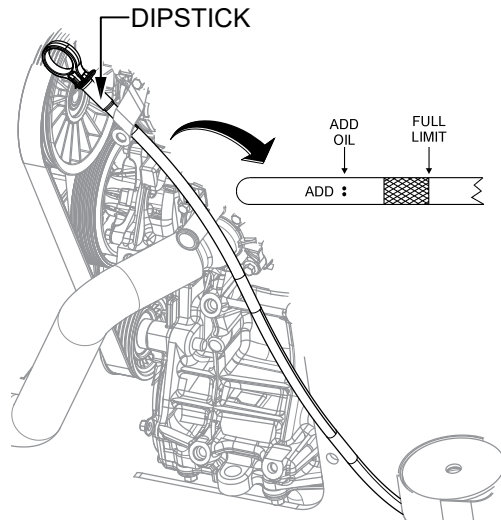

Figure 20. Engine Oil Dipstick

3. Fully insert the dipstick then remove it again.
4. Determine if engine oil is low. Oil should be between the upper and lower marks (Figure 20) on the dipstick.
5. If the oil is below the lower mark on the dipstick, remove the oil filler cap (Figure 21) and add engine oil up to the upper mark on the dipstick. Refer to Table 6 for recommended oil viscosity.

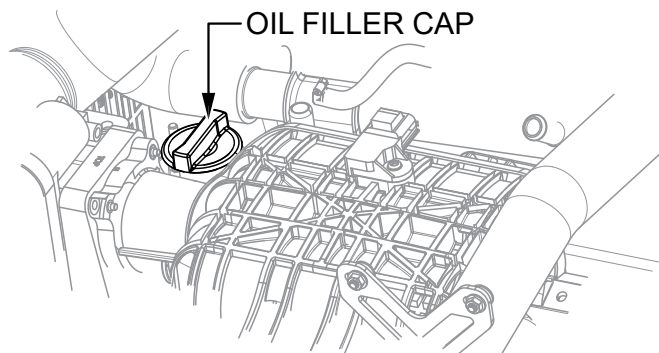
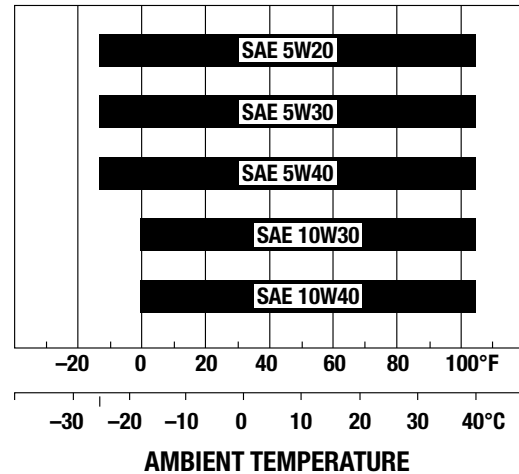

Figure 21. Oil Filler Cap

! CAUTION

NEVER overfill the oil pan. **ALWAYS** allow time for any added oil to make its way to the oil pan before rechecking the level.

Table 6. Recommended Oil Viscosity Grades



NOTICE

To maintain proper engine performance and durability, use only engine oils with an API classification of SJ or SH. **NEVER** use supplemental oil additives or other engine treatments.

6. When replacing the dipstick, make sure it is fully inserted into its holder to keep the crankcase sealed.

HYDRAULIC OIL

1. Make sure the trowel is secured on a level surface with the engine stopped.
2. Raise the lifting bail and open the main hood of the trowel as shown in Figure 22.

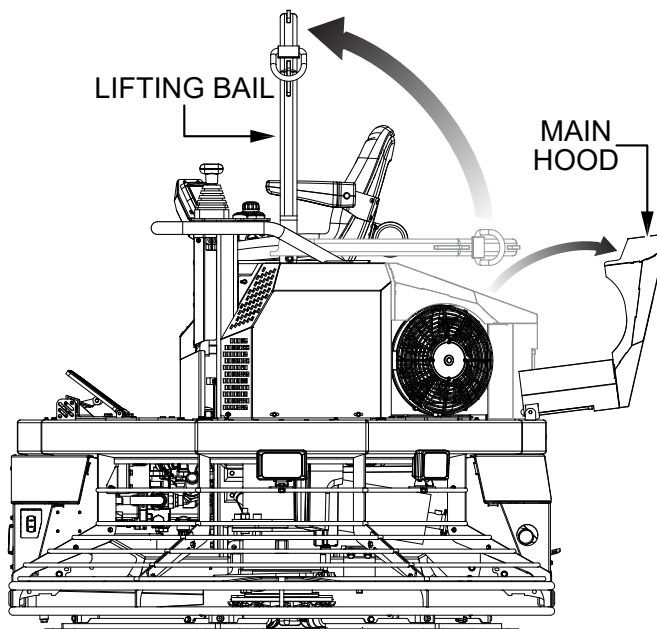

Figure 22. Lifting Bail and Main Hood

3. Turn the ignition key to the **ON** position and press the **F3** button to access the machine information screen.
4. Press the **down arrow button** to scroll downward until **HYD LEVEL** (Figure 23) is displayed on the screen. The hydraulic oil level should be 20–75% when the oil is cold.

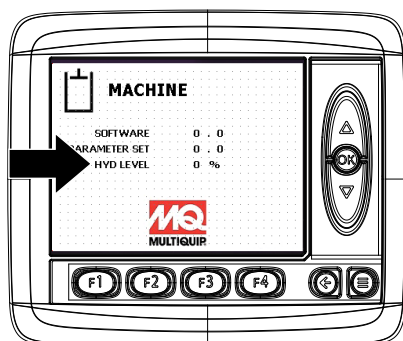

Figure 23. Hydraulic Oil Level Display

5. An alternative method for checking the level of hydraulic oil is to visually inspect the level through the window at the rear of the hydraulic oil reservoir (Figure 24). Hydraulic oil should be visible between the **MIN** and **MAX** lines next to the window.

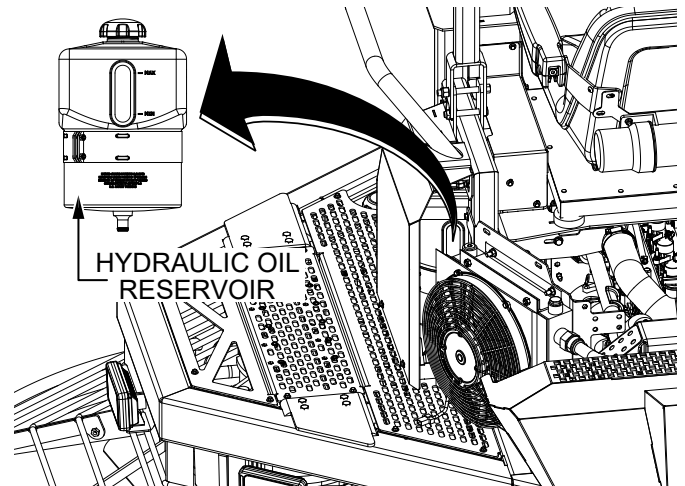

Figure 24. Hydraulic Oil Level Inspection

6. If the hydraulic oil level is low, the hydraulic oil reservoir cover will need to be removed in order to access the hydraulic oil fill cap. Remove the five bolts securing the cover to the frame (Figure 25). Set the cover and bolts aside.

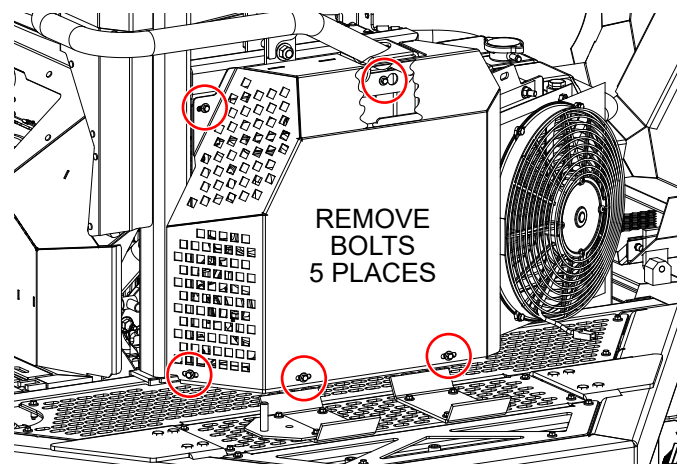



Figure 25. Hydraulic Oil Reservoir Cover Removal

INSPECTION

7. Remove the hydraulic oil filler cap (Figure 26).

CAUTION



Hydraulic oil can get **HOT!**
ALWAYS allow hydraulic oil to cool before removing the fill cap. **NEVER** remove the fill cap when the oil is hot or spillage will occur.

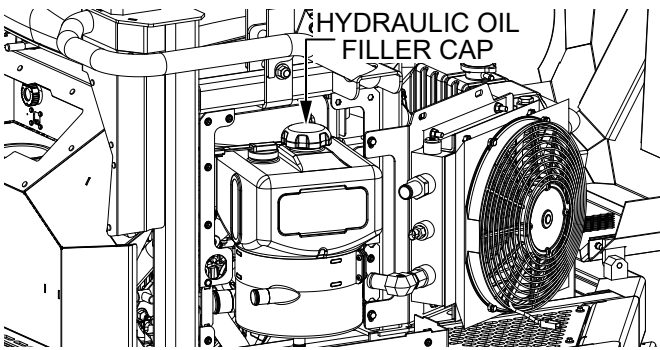

Figure 26. Hydraulic Oil Filler Cap

8. Add hydraulic oil up to a level midway between the **MIN** and **MAX** lines on the reservoir or 50% as shown on the digital display when the oil is cold. **DO NOT** overfill. Use only Parker DuraClean™ ISO 46 hydraulic oil. Replace the filler cap when finished.
9. Reinstall the hydraulic oil reservoir cover with the five bolts that were removed earlier.

FUEL CHECK (GASOLINE)

DANGER

Gasoline fuel is **highly flammable** and can be dangerous if mishandled.

NEVER smoke while refueling. **NEVER** attempt to refuel while the engine is hot or running.

1. Make sure the trowel is secured on a level surface with the engine stopped.

2. Turn the ignition key to the **ON** position and read the fuel gauge on the digital display (Figure 27) to determine if the gasoline level is low.

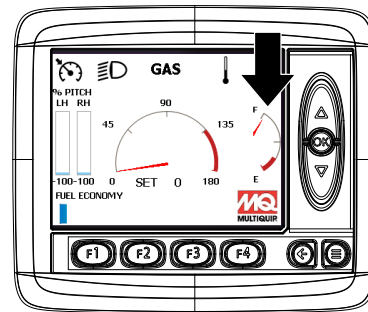



Figure 27. Fuel Check (Gasoline)

3. If fuel is low, remove the red fuel filler cap (Figure 28) and fill the tank with unleaded 87 or 89 octane gasoline. **DO NOT** overfill. The fuel tank holds 14.5 gallons (55 liters) of gasoline.

DANGER



Fuel spillage on a **hot** engine can cause a **fire** or **explosion**. If fuel spillage occurs, wipe up the spilled fuel completely to prevent fire hazards. **NEVER** smoke around or near the trowel.

NOTICE

Using lower than 87 octane gasoline may cause heavy pinging resulting in engine damage.

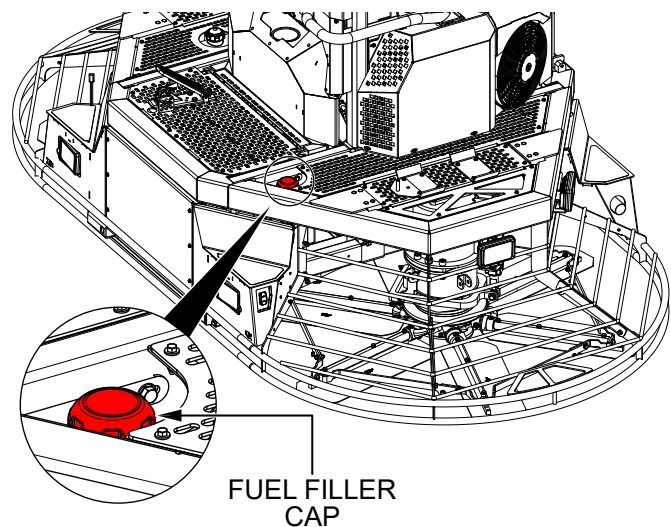

Figure 28. Fuel Filler Cap (Gasoline)

4. Replace the fuel filler cap when finished adding fuel.

FUEL CHECK (PROPANE)

1. Turn the LPG shutoff valve (Figure 29) clockwise until closed.

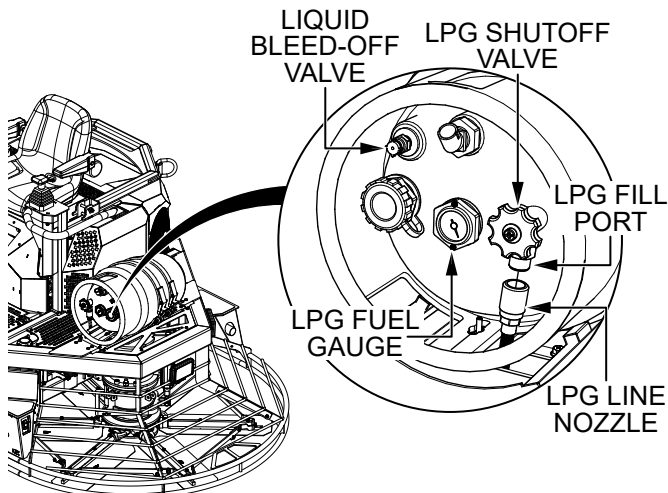

Figure 29. LPG Shutoff Valve

2. Read the fuel gauge (Figure 30) on the propane tank to determine if the propane level is low.

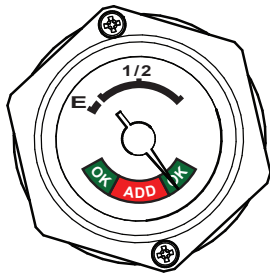

Figure 30. LPG Fuel Gauge

Propane Tank Removal

The propane tank can be refueled while in place (attached to the trowel), or can be removed and replaced with a full tank. Refer to Figure 31 when removing and replacing the propane tank:

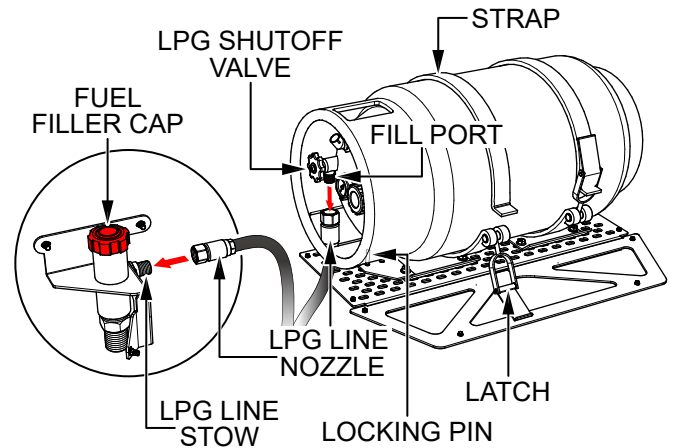

Figure 31. Propane Tank Removal

1. Make sure the trowel is secured on a level surface with the engine stopped.
2. Turn the LPG shutoff valve clockwise until closed.
3. Disconnect the LPG line nozzle from the propane tank fill port.
4. Connect the LPG line nozzle to the LPG line stow located next to the red gasoline fuel filler cap.
5. Release the latches on the propane tank straps.
6. Push backward and lift upward to remove the propane tank.
7. Place the new propane tank onto the tank bracket. Align the locking slot with the locking pin on the tank bracket.
8. Secure the latches on the propane tank straps.
9. Reconnect the LPG line nozzle to the propane tank fill port.
10. Turn the LPG shutoff valve counterclockwise to open.

WARNING

Engines using LPG fuel should be operated only in areas with adequate ventilation. **NEVER** operate in confined areas or in areas where the free flow of air is restricted.

OPERATION

The following section is intended to assist the operator with operation of the trowel. It is extremely important to read this section carefully before attempting to use the trowel in the field. **DO NOT** operate the trowel until this section is thoroughly understood.

CAUTION



ALWAYS wear approved eye and hearing protection while operating the trowel.

WARNING



NEVER operate the trowel in a confined area or enclosed area structure that does not provide an ample free flow of air.

NOTICE

This trowel is equipped with a safety seat switch. The trowel blades will not rotate unless an operator is sitting in the seat or the drive bypass function is enabled.

STARTING THE ENGINE

1. While standing in front of the trowel, grasp one of the grab bars and place a foot on one of the steps. Lift yourself onto the trowel platform and sit down in the operator's seat.

NOTICE

DO NOT grab the steering control joysticks to lift yourself onto the trowel. Damage to the joysticks may result. **ALWAYS** use the grab bars to lift yourself onto the trowel.

2. Insert the **ignition key** into the ignition switch (Figure 32).

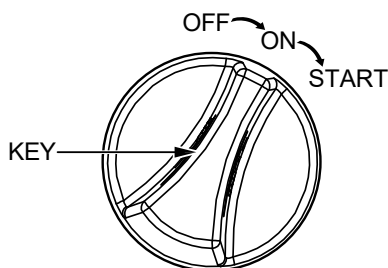

Figure 32. Ignition Key Switch

3. Turn the ignition key clockwise to the **ON** position (Figure 32). The **digital display** will turn on and the menu screen (Figure 33) will appear on the display.

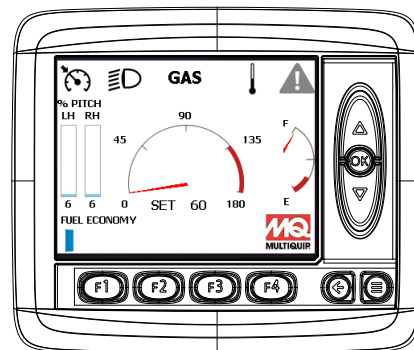

Figure 33. Digital Display (Menu Screen)

4. Select **GAS** or **LPG** fuel mode. Press the **fuel selector button** (Figure 34) to toggle between gasoline and LPG fuel systems. The button will illuminate when LPG is selected. The selected fuel system is also shown on the digital display.

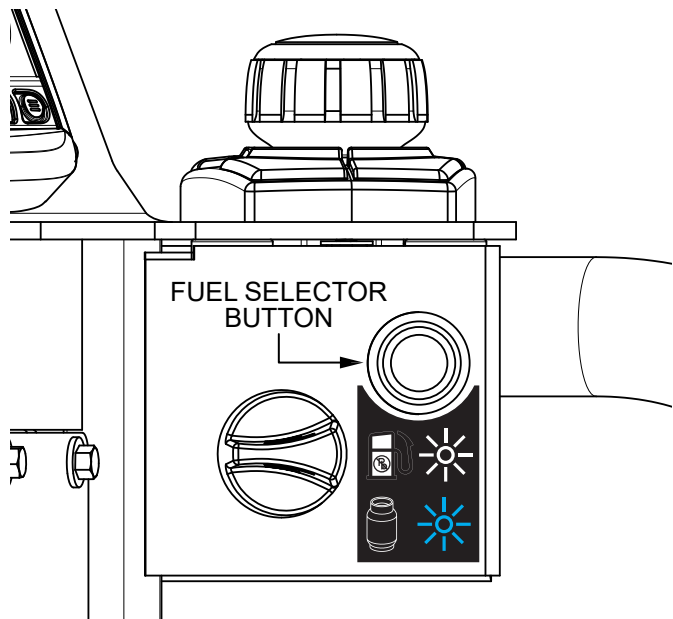

Figure 34. Fuel Selector Button

NOTICE

Fuel modes can be switched while the trowel is running. The engine does not need to be stopped when changing between fuel modes.

5. Press the **RPM button** to view the **maximum rotor speed adjustment screen** on the digital display (Figure 35).

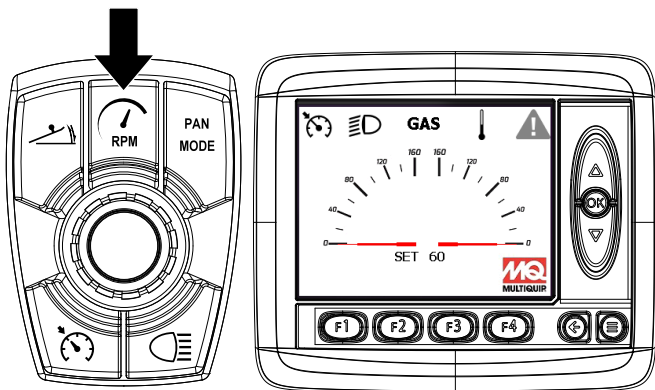

Figure 35. Digital Display (Rotor Speed)

6. Turn the **control knob** until the desired rotor speed (60–150 rpm) is displayed. During normal operation this will be the blade speed when the foot pedal is fully depressed. See Figure 36.

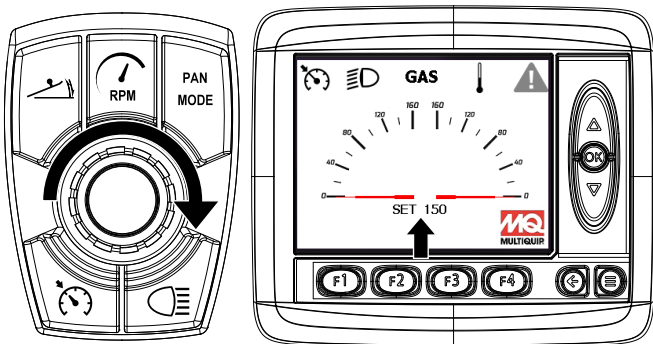

Figure 36. Rotor Speed Selection

7. Blade pitch can be set independently for each rotor (single pitch) or for both rotors simultaneously (dual pitch). Press the **blade pitch button** to view the **blade pitch adjustment screen** on the digital display (Figure 37).

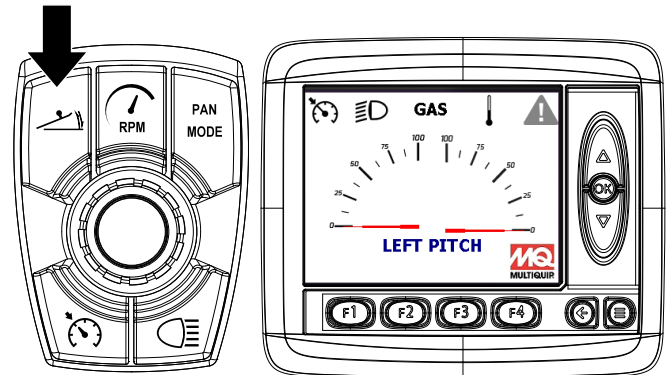

Figure 37. Digital Display (Blade Pitch)

8. Press the **control knob** (Figure 38) to toggle through the left, right, and dual pitch options.

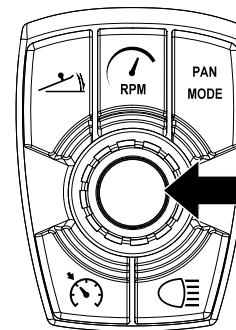

Figure 38. Control Knob

9. Turn the **control knob** until the desired blade pitch is displayed (Figure 39).

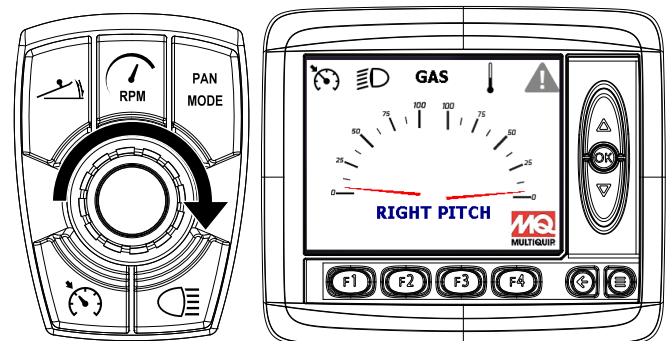

Figure 39. Blade Pitch Selection

- Turn the ignition key fully clockwise to the **START** position. Once the engine has started, release the ignition key. The throttle speed will default to idle to allow the engine to warm to operating temperature.

NOTICE

Engine Speed Safety Interlocks

Full engine speed is only possible when the operator is seated. Engine speed will decrease to idle whenever the operator leaves the seat or the foot pedal is released for more than 3 seconds.

- Let the engine idle for 2–3 minutes.
- If the fault icon on the digital display turns **AMBER** or **RED**, shut down the engine and correct the problem. Press the **F1** button to view active faults. The digital display will show a fault code and a description of the problem. Refer to Table 12–Table 20 for a list of engine and machine fault codes.

Cold Start Mode

If the engine coolant temperature is below 160°F or the hydraulic oil temperature is below 100°F, the temperature indicator on the display will turn **blue** (Figure 40) to indicate **Cold Start mode** is enabled.

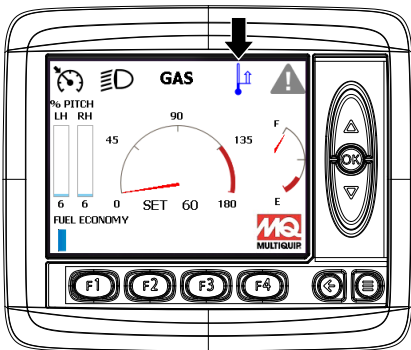

Figure 40. Temperature Indicator (Cold Start ON)

In Cold Start mode, the engine speed is raised to 1,750 rpm to heat the system up quickly, and a valve is opened to allow hydraulic oil to bypass the hydraulic coolers.

Cold Start mode will remain enabled until the hydraulic oil temperature rises above 100°F, the engine coolant temperature rises above 160°F, or after a 30-minute default time. The temperature indicator on the display will turn **black** (Figure 41) to indicate Cold Start mode has been disabled.

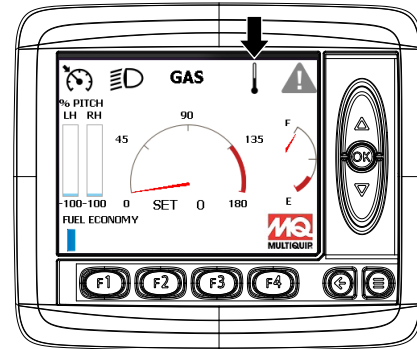

Figure 41. Temperature Indicator (Cold Start OFF)

NOTICE

Although the trowel will still function while in Cold Start mode, it is **highly recommended** that the system be allowed to fully warm up prior to operation.

TESTING THE SEAT SWITCH

Make sure the safety seat switch is operational prior to using the trowel each day.

- With the engine running, depress the foot pedal to start rotating the blades. Observe that the blades are rotating.
- Rise from the operator's seat.
- Verify that the blades stop rotating while the engine continues to run.
- If blade rotation has stopped, the seat switch is working.
- If blade rotation continues, the seat switch is not working. Stop the engine immediately and correct the problem.

WARNING

NEVER disable or disconnect the seat switch. It is provided for operator safety. Injury may result if it is disabled, disconnected or improperly maintained.

CRUISE CONTROL

Engaging **cruise control** will set and maintain rotor speed. The cruise control feature allows an operator to release the foot pedal during operation and adjust rotor speed using the digital controls.

1. Set the rotor speed as described in the **Starting the Engine** section.
2. Depress the **foot pedal** (Figure 42) to raise the rotor speed to the set speed.

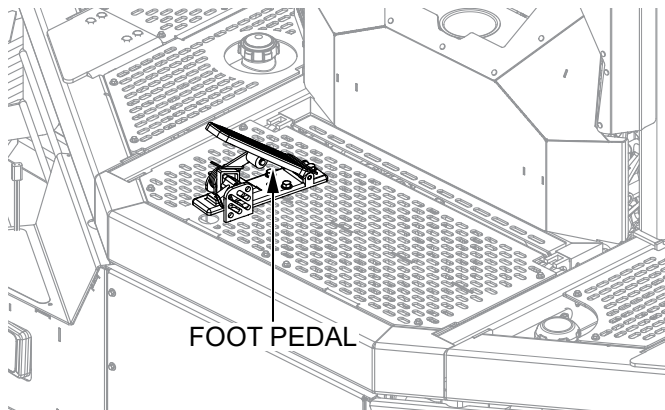

Figure 42. Foot Pedal

3. Press the **cruise control button** (Figure 43). The cruise control icon on the digital display will turn green to indicate cruise control is engaged.

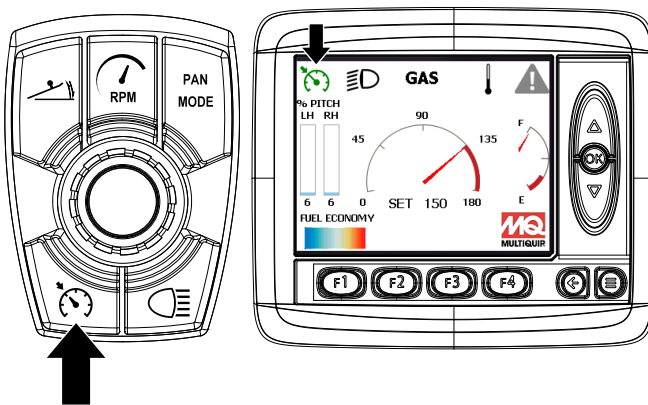

Figure 43. Cruise Control

4. Release the foot pedal. The rotors should maintain the set speed.
5. Rotor speed can now be changed without disengaging cruise control. Set a new rotor speed using the maximum rotor speed adjustment function or simply turn the control knob while the main display screen is active.

6. Disengage cruise control by doing any of the following:
 - Press the foot pedal.
 - Stand up from the operator's seat.
 - Press the control knob to lower engine speed.
 - Press the cruise control button.

NOTICE

Cruise Control Safety Interlocks

Cruise control will be disabled if the following occurs:

- Operator presence is not detected (not sitting in seat).
- An engine or machine fault code is active.
- A drive bypass switch is pressed.
- The foot pedal calibration process has been started.

STEERING

Two palm-grip joysticks (Figure 44) located to the left and right of the operator's seat provide directional control of the trowel.

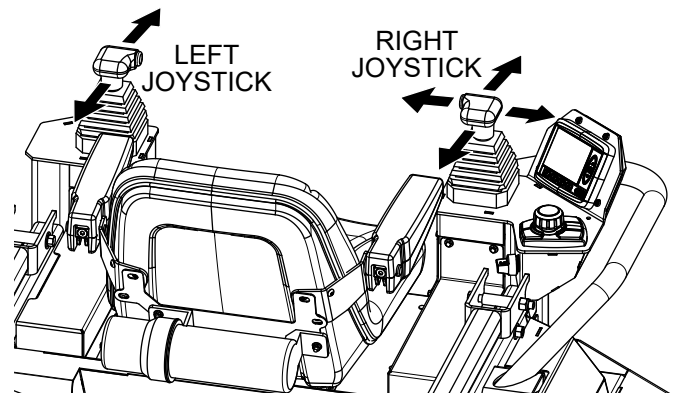

Figure 44. Steering Control Joysticks

OPERATION

Table 7 illustrates the various directional positions of the joysticks and their effect on the movement of the trowel.

NOTICE

All directional references with respect to the joysticks are from the operator's seat position.

Table 7. Joystick Directional Positioning

CONTROL JOYSTICK & DIRECTION	RESULT
Move LEFT Joystick FORWARD ↑	Causes only the left side of the ride-on trowel to move forward.
Move LEFT Joystick BACKWARD ↓	Causes only the left side of the ride-on trowel to move backward.
Move RIGHT Joystick FORWARD ↑	Causes only the right side of the ride-on trowel to move forward.
Move RIGHT Joystick BACKWARD ↓	Causes only the right side of the ride-on trowel to move backward.
Move BOTH Joysticks FORWARD ↑ ↑	Causes the ride-on trowel to move forward in a straight line.
Move BOTH Joysticks BACKWARD ↓ ↓	Causes the ride-on trowel to move backward in a straight line.
Move RIGHT Joystick to the RIGHT →	Causes the ride-on trowel to move to the right.
Move RIGHT Joystick to the LEFT ←	Causes the ride-on trowel to move to the left.

- The **foot pedal** (Figure 45) controls rotor speed when cruise control is disengaged. The position of the foot pedal determines the rotational speed of the blades. Slow blade speed is obtained by slightly depressing the foot pedal. Maximum blade speed is obtained by fully depressing the foot pedal.

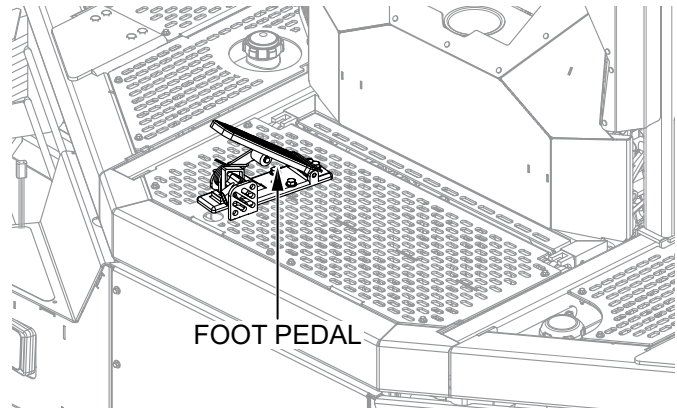

Figure 45. Foot Pedal

- Push both the left and right joysticks forward (Figure 46).

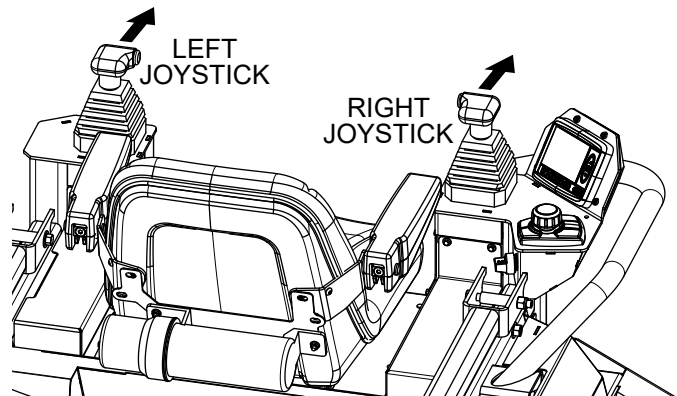

Figure 46. Joysticks (Forward)

- With your right foot, slowly depress the foot pedal **halfway**. Notice that the trowel begins to move in a forward direction. Release both joystick controls to stop forward movement, then remove your right foot from the foot pedal.
- Practice holding the machine in one place as you increase blade speed. When about 75% of maximum blade speed has been reached, the blades will be moving at proper finishing speed. The machine may be difficult to keep in one place. Trying to keep the trowel stationary is good practice for operation.

- Practice maneuvering the trowel using the information in Table 7. Practice controlled motions as if finishing a slab of concrete. Practice edging and covering a large area.
- Try adjusting the pitch of the blades. This can be done with the trowel stopped or while the trowel is moving.
- Test the operation of additional equipment like retardant spray and lights.
- Pull both the left and right joysticks backward (Figure 47) and repeat steps 3–4 while substituting the word *reverse* for *forward*.

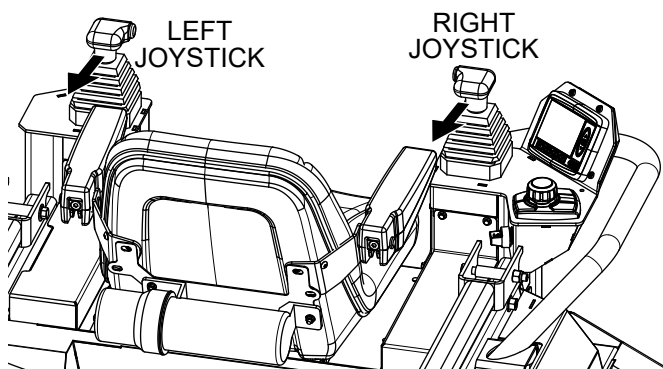

Figure 47. Joysticks (Reverse)

CONTROLLING ENGINE SPEED

Do any of the following to **raise engine speed** to operating speed from idle:

- Press the control knob while the digital display is on the main screen.
- Depress the foot pedal while sitting in the operator's seat.
- Press and hold a drive bypass switch.

Do any of the following to **lower engine speed** to idle from operating speed:

- Press the control knob while the digital display is on the main screen and the foot pedal is not pressed.
- Release the foot pedal and wait for 3 seconds.
- Rise from the operator's seat.
- Release a drive bypass switch.

Engine Idle

The trowel has two engine idle speeds: 900 rpm and 1,750 rpm. The engine will idle at the higher speed of 1,750 rpm when any of the following are true:

- Cold start mode is active.
- Trowel lights are on.
- Hydraulic cooling fans are on.
- Battery voltage is low.

PANNING MODE

When **panning mode** is activated, the trowel blades are pitched flat and the pitch systems are retracted to allow for the use of float pans.

To activate panning mode, press and hold the **panning mode button** (Figure 48) for 3 seconds.

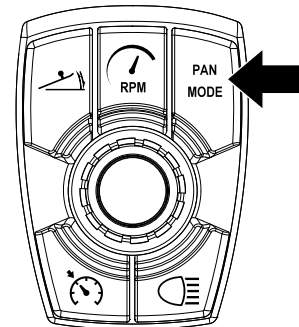

Figure 48. Panning Mode Button

NOTICE

For float pan installation instructions, refer to the **Maintenance** section of this manual.

REMOVING THE TROWEL FROM A CONCRETE PAD

Care should be taken to prevent damage to a concrete pad surface while removing the trowel from the pad. This procedure will require at least two people—one to operate the forklift and one to carefully rotate the blades.

WARNING

Removal of the trowel from concrete requires **two people**. **NEVER** attempt to perform this procedure alone!

WARNING

DO NOT place any part of your body between the forklift and the trowel. **SERIOUS INJURY OR DEATH** may result.

1. With the engine running at idle, carefully attach the trowel to a forklift as shown in the **Lifting and Transporting** section of this manual.
2. **Without sitting in the operator's seat**, press and hold one of the **drive bypass switches** (Figure 49). Engine speed will rise to operating speed and **the trowel lights will flash** to remind personnel to **exercise caution** while turning the blades during this procedure.

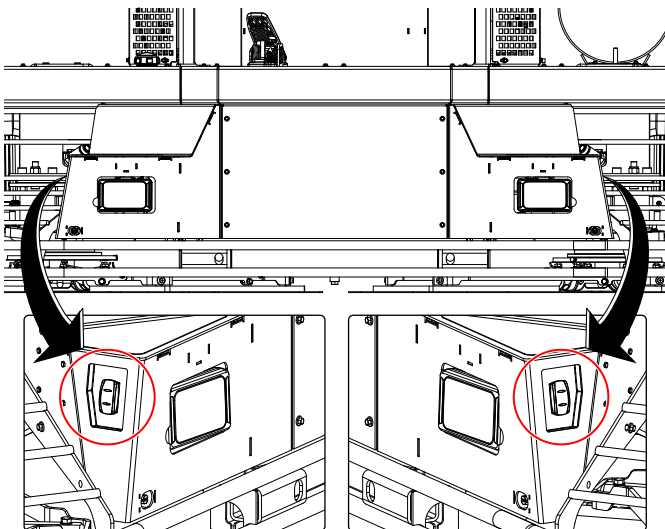

Figure 49. Drive Bypass Switches

NOTICE

DO NOT engage the seat switch by sitting in the operator's seat. The blades will not turn if an operator is in the seat while a drive bypass switch is pressed. In drive bypass mode, the rotors are only turned via drive bypass switch and foot pedal engagement.

3. While continuing to hold one of the drive bypass switches, press the foot pedal (by hand) to slowly rotate the trowel blades.
4. With the trowel blades slowly rotating, use the forklift to slowly lift the trowel until all trowel blades are clear of the concrete pad surface. Remember to **keep all personnel out of the area** between the forklift and the trowel.
5. Release the drive bypass switch and foot pedal, and stand clear of the forklift and trowel.

ENGINE SHUTDOWN

1. Reduce engine speed and allow the engine to idle for 3–5 minutes.

NOTICE

Failure to allow the engine to idle for a few minutes before shutdown may lead to damage.

2. Turn the ignition key counterclockwise to the **OFF** position, then remove the key.
3. If LPG mode was in use, turn the **propane shutoff valve** clockwise (Figure 50) until closed.

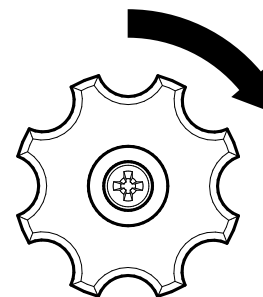

Figure 50. Propane Tank Shutoff Valve (Closed)

4. Clean and remove any debris from the trowel.

Table 8. Maintenance Schedule

Check Item	Daily	Periodic Maintenance Interval									
		Every 200 hours	Every 400 hours	Every 800 hours	Every 1,000 hours	Every 1,250 hours	Every 1,500 hours	Every 1,750 hours	Every 2,000 hours	Every 3,000 hours	Every 5,000 hours
General Maintenance											
Visual check for fluid leaks	X										
Check engine oil level	X										
Check coolant level	X										
Change engine oil and filter ¹			X								
Change hydraulic oil ²							X				
Check LPG system for leaks	Prior to any service or maintenance activity										
Inspect drive belt for cracks, breaks, splits or glazing ³		X									
Inspect electrical wiring for cuts, abrasions or corrosion	After the first 50 hours of operation, then after every 100 hours of operation										
Check all fasteners for tightness			X								
Replace all spider assembly bolts and washers	Every 100 hours of operation										
Engine Cooling System											
Clean debris from radiator core	Every 100 hours or 60 days of operation										
Change coolant ⁴							X				
Inspect coolant hoses for cracks, swelling or deterioration ³	After the first 50 hours of operation, then after every 100 hours of operation										
Engine Ignition System											
Replace spark plugs			X								
Inspect battery case for damage					X						
Base Engine System											
Inspect PCV system				X							
<p>Note 1 = Oil life is highly dependent on oil quality, operating environment, and engine use.</p> <p>Note 2 = Use Parker DuraClean™ ISO 46 hydraulic oil only.</p> <p>Note 3 = Item should be checked yearly, replaced as needed.</p> <p>Note 4 = Ford requires the use of Motorcraft® Premium Gold engine coolant or antifreeze meeting Ford specification WSS-M97B51-A1. Changing of coolant types (typically indicated by color) and mixing of coolants is not allowed as this can result in a loss of coolant protection during the engine life.</p>											

MAINTENANCE

Table 9. Maintenance Schedule (Continued)

Check Item	Daily	Periodic Maintenance Interval									
		Every 200 hours	Every 400 hours	Every 800 hours	Every 1,000 hours	Every 1,250 hours	Every 1,500 hours	Every 1,750 hours	Every 2,000 hours	Every 3,000 hours	Every 5,000 hours
Fuel System Maintenance											
Inspect air cleaner	Every 200 hours, or every 100 hours in dusty environment										
Replace air cleaner	Every 800 hours, or every 400 hours in dusty environment										
Check gasoline fuel filter	X										
Check LPG fuel filter	X										
Check fuel lines for leaks	After the first 50 hours of operation, then after every 100 hours of operation										
Check air induction for leaks											
Check manifold for vacuum leaks											
Drain LPG vaporizer oil buildup	Every 150 hours or 120 days of operation										
Engine Exhaust System											
Inspect exhaust manifold for leaks	After the first 50 hours of operation, then after every 100 hours of operation										
Inspect exhaust piping for leaks											
Check HEGO sensor(s) connector and wires for burns, cuts or damage									X		
This maintenance schedule represents the manufacturer's recommended maintenance intervals to maintain proper engine/equipment function. Specified state and federal regulations may require equipment operators to conduct comprehensive engine/equipment inspections at more periodic intervals than those specified above.											

CAUTION

Certain maintenance operations or machine adjustments require specialized knowledge and skill. Attempting to perform maintenance operations or adjustments without the proper knowledge, skills or training could result in equipment damage or injury to personnel. When in doubt, consult your dealer.

AIR CLEANER

The Ford MSG-425 engine is equipped with a disposable, replaceable air cleaner (Figure 51). The air cleaner housing and filter form one unit with no serviceable parts. Simply remove and replace the entire air cleaner unit.

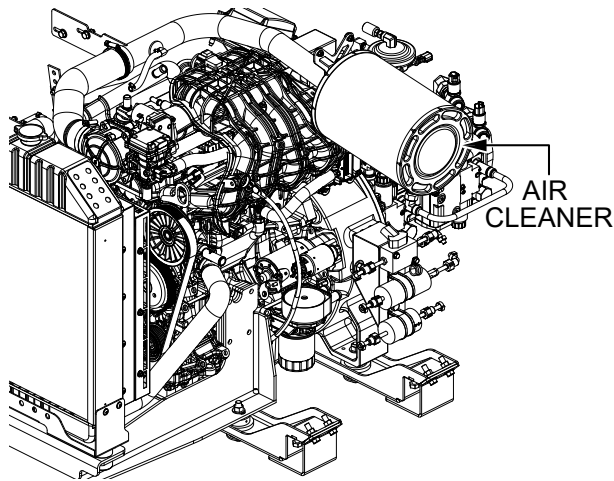

Figure 51. Engine Air Cleaner

NOTICE

Visually inspect the air cleaner daily before operation. Replace the air cleaner if it is damaged or excessively dirty. **NEVER** wash or clean the air cleaner for reuse.

1. Make sure the trowel is secured on a level surface with the engine stopped.
2. Raise the lifting bail and open the main hood of the trowel.
3. Remove the five bolts securing the right-side cover (Figure 52) to the frame. Set the cover and bolts aside.

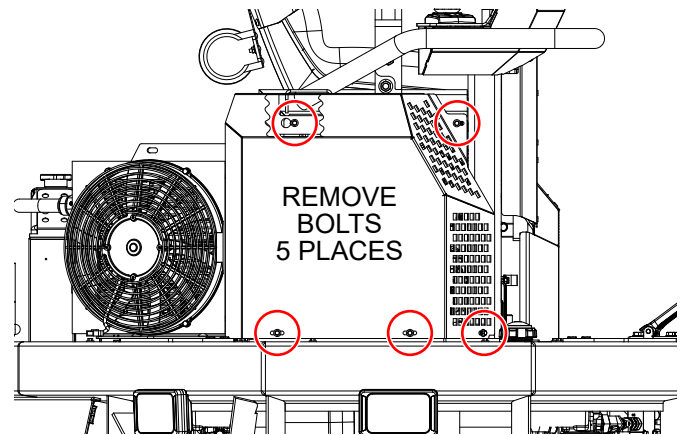

Figure 52. Right-Side Cover Removal

4. Remove and set aside the hose clamp securing the air cleaner to the filter hose (Figure 53).

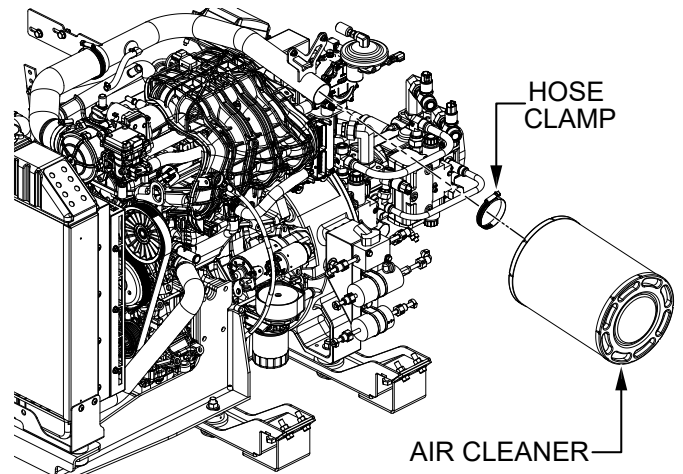

Figure 53. Air Cleaner Removal

5. Remove and discard the existing air cleaner.
6. Install the new air cleaner with the existing hose clamp.
7. Reinstall the right-side cover.

NOTICE

NEVER run the engine with the air cleaner removed.

NOTICE

Operating the engine with a loose or damaged air cleaner could allow unfiltered air into the engine, causing premature wear and failure.

RADIATOR/COOLING SYSTEM

CAUTION



Hot coolant can cause severe burns. **NEVER** remove the cap while the radiator is **HOT**.

NOTICE

The engine manufacturer recommends that the cooling system be filled with a 50/50 mixture of Motorcraft® Premium Gold engine coolant and clean water.

1. Check the radiator for leaks that would indicate corrosion or damage.
2. Check the coolant/antifreeze level daily and top off as necessary. Always mix coolant with clean, soft water and use the mixing ratios specified by the engine manufacturer. Replace coolant/antifreeze at least once a year.
3. Check radiator hoses for fatigue or cracking and replace as necessary.
4. Check the radiator cap seal and replace as necessary.

Radiator Cleaning

1. Blow off dirt and dust from the radiator and fins with 28 psi (193 kPa) or less of compressed air (Figure 54). Be careful to not damage the fins with the compressed air.

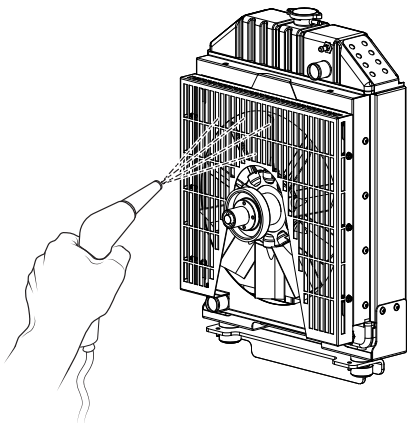

Figure 54. Radiator Cleaning

2. If there is a large amount of contamination on the fins, clean and rinse them thoroughly with detergent and tap water.

CAUTION

Radiator fins damage easily. **NEVER** use high-pressure water, a wire brush, or compressed air at greater than 28 psi (193 kPa) to clean the radiator fins.

SERPENTINE DRIVE BELT

The serpentine drive belt needs to be changed as soon as it begins to show signs of wear. **NEVER** reuse a belt under any circumstances. Indications of excessive belt wear include:

- Fraying
- Excessive noise
- Belt instability
- Constant or reoccurring squeal
- Smoke
- Smell of burning rubber

Visually inspect the drive belt every 200 hours of use for signs of damage or excessive wear (Figure 55). Replace the drive belt if it is worn or damaged.

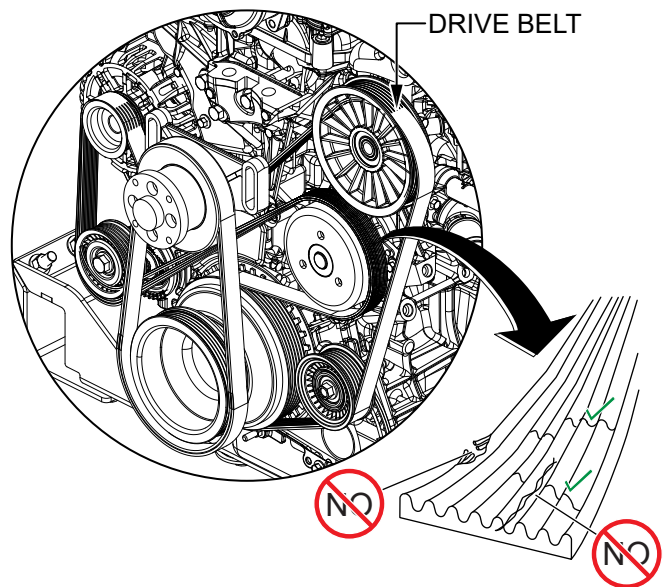

Figure 55. Drive Belt Inspection

WARNING



NEVER insert hands or tools into the drive belt area while the engine is running. Keep fingers, hands, hair and clothing away from all moving parts to prevent bodily injury.

WARNING



DO NOT attempt to access the drive belt until the muffler has cooled. Allow the entire trowel to cool down before performing this procedure.

BELT TENSION

The serpentine drive belt is automatically tensioned and does not require adjustment.

The fan belt (Figure 56) should be tensioned to 95–100 lb. The bearing bracket bolts should be torqued to 21 lbf-ft.

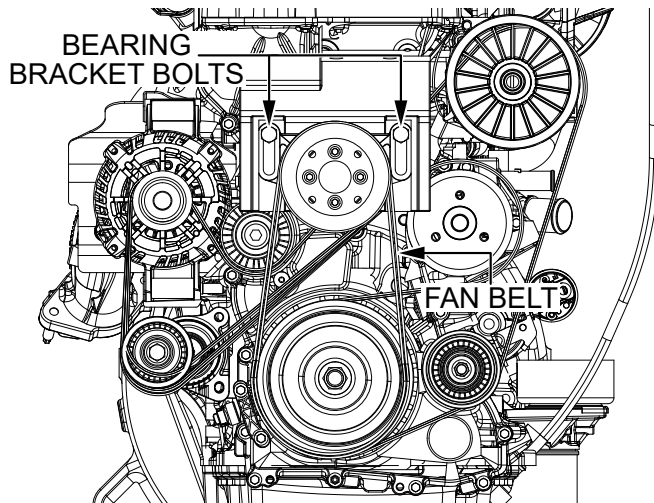

Figure 56. Fan Belt Tension and Bolt Torque

ENGINE OIL

1. Make sure the trowel is secured on a level surface with the engine stopped.

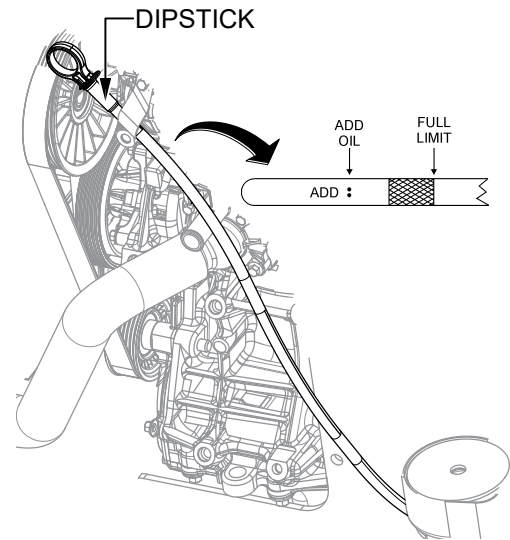

Figure 57. Engine Oil Dipstick

2. Pull the engine oil dipstick (Figure 57) out of its holder and wipe it with a clean rag.
3. Fully insert the dipstick then remove it again.
4. Determine if engine oil is low. Oil should be between the upper and lower marks (Figure 57) on the dipstick.
5. If the oil is below the lower mark on the dipstick, remove the oil filler cap (Figure 58) and add engine oil up to the upper mark on the dipstick. Refer to Table 6 for recommended oil viscosity.

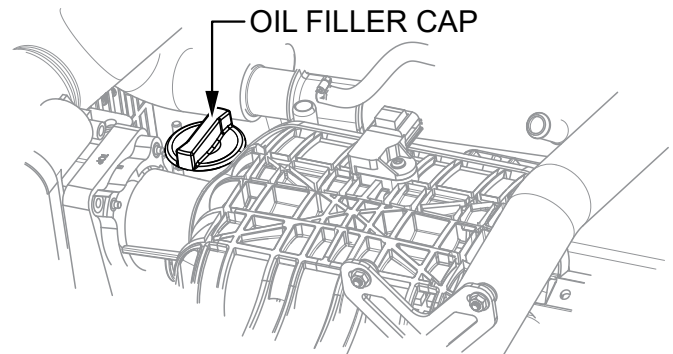

Figure 58. Oil Filler Cap

CAUTION

NEVER overfill the oil pan. **ALWAYS** allow time for any added oil to make its way to the oil pan before rechecking the level.

NOTICE

To maintain proper engine performance and durability, use only engine oils with an API classification of SJ or SH. **NEVER** use supplemental oil additives or other engine treatments.

- When replacing the dipstick, make sure it is fully inserted into its holder to keep the crankcase sealed.

Changing Engine Oil And Filter

Change the engine oil and filter every 400 hours of operation. Refer to Table 6 for recommended oil viscosity.

NOTICE

ALWAYS drain the engine oil while the oil is **warm**.

- Remove the oil filler cap to allow the oil to drain easily.
- Remove the oil drain bolt and sealing washer (Figure 59). Allow the oil to drain into a suitable container.

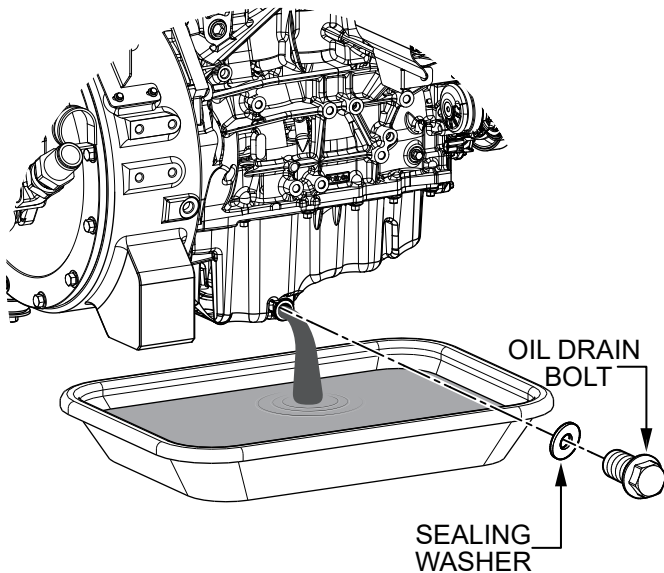

Figure 59. Engine Oil Replacement

- After the oil has fully drained, reinstall the oil drain bolt and sealing washer and tighten securely.

- Using a filter wrench (Figure 60), turn the oil filter counterclockwise to remove.

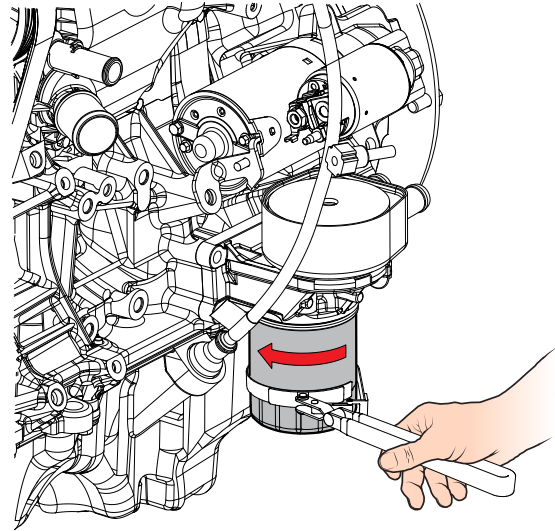

Figure 60. Oil Filter Removal

- Clean the sealing surface where the filter mounts onto the engine.
- Coat the seal of the new oil filter (Figure 61) with clean engine oil. Install the new filter by hand until it contacts the engine sealing surface, then tighten it another 1/2 turn. **DO NOT** use a strap wrench or similar tool to tighten the filter.

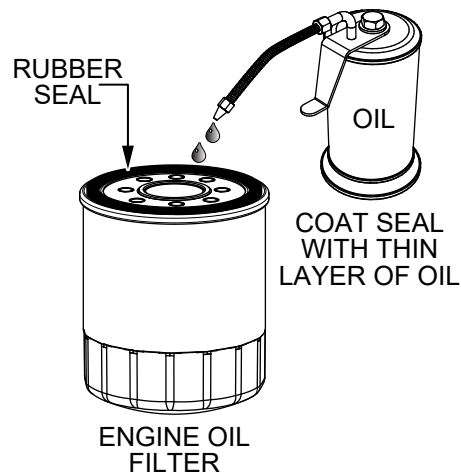

Figure 61. Oil Filter

- Fill the engine with oil via the filler neck. Refer to Table 3 for engine oil capacity. **DO NOT** overfill.
- Replace the filler cap and run the engine for no more than 30 seconds. Recheck the oil level and top off as needed.

FUEL TANK

Removing Water from the Fuel Tank

After prolonged use, water and other impurities will accumulate in the bottom of the fuel tank. Occasionally inspect the fuel tank for water contamination and drain the contents if necessary.

The emptier the fuel tank, the easier it is for water to condense inside. This is especially true in cold weather. Keeping the tank filled with unleaded gasoline will reduce this effect.

NOTICE

NEVER store the trowel with fuel in the tank for an extended period of time. Completely drain the fuel system (tank, lines, etc.) if the unit is to be put into long-term storage.

For short-term storage, the tank should be filled to avoid condensation that could cause contamination of the fuel.

Cleaning Inside the Fuel Tank

If necessary, completely drain the fuel inside the fuel tank. Use a spray washer to wash out any debris or deposits that have accumulated inside the tank.

Fuel System Inspection

The following components should be inspected for wear:

- **Fuel Hoses** — Inspect nylon and rubber hoses for signs of wear, deterioration or hardening.
- **Fuel Tank Lining** — Inspect the fuel tank lining for excessive amounts of oil or other foreign matter.

FUEL FILTER

1. Replace the engine fuel filter (Figure 62) every 200 hours of operation.

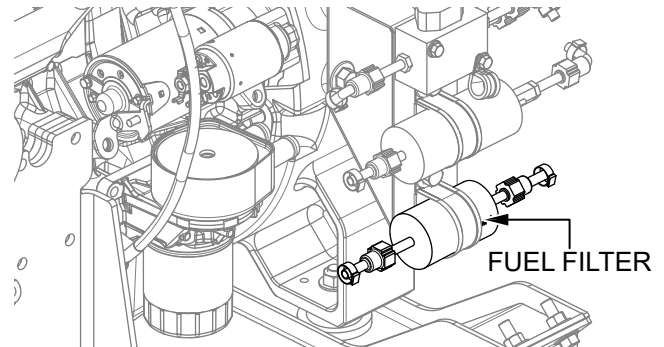

Figure 62. Fuel Filter

Spark Plugs

1. Make sure the engine is cool before servicing the spark plugs.
2. Loosen the spark plugs and remove any dirt from around the spark plug area.
3. Remove and inspect the spark plugs. Replace the spark plugs if they are damaged, the sealing washer is in poor condition, or the electrode is worn.
4. Measure the spark plug electrode gap (Figure 63) with a wire-type feeler gauge. If needed, adjust the gap to 0.049–0.053 in. (1.25–1.35 mm) by carefully bending the side electrode.

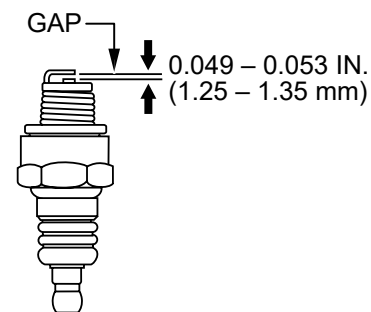

Figure 63. Spark Plug Gap Adjustment

5. Install the spark plug carefully, by hand, to avoid cross-threading.
6. After the spark plug is seated, tighten with a spark plug wrench to 11 lbf-ft. (15 N·m).

OIL AND FUEL LINES

1. Check the oil and fuel lines and connections regularly for leaks or damage and replace as necessary.
2. Replace the oil and fuel lines every two years to maintain flexibility and performance.

HYDRAULIC OIL AND FILTER

The digital display will show a fault code and warning to indicate that the hydraulic oil filter (Figure 64) has become clogged. Replace the hydraulic oil and filter using 10-micron absolute synthetic media filters.

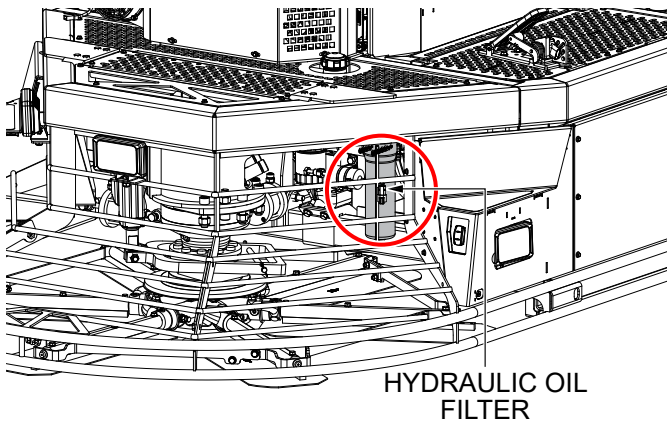

Figure 64. Hydraulic Oil Filter

Draining the Hydraulic Oil

CAUTION



Hydraulic oil can get **HOT!**

ALWAYS allow hydraulic oil to cool before performing this procedure.

1. Locate the hydraulic oil drain hose (Figure 65) attached to the bottom of the hydraulic oil reservoir.

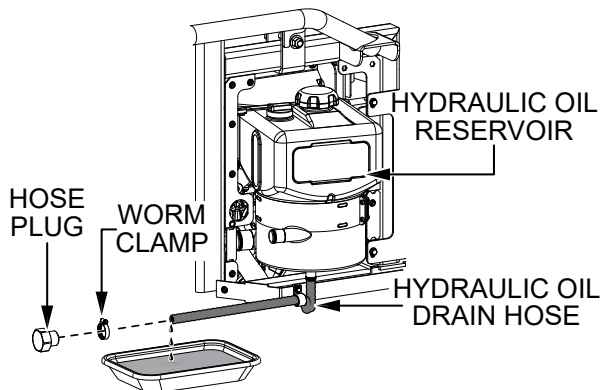

Figure 65. Draining Hydraulic Oil

2. Place an appropriate container beneath the hydraulic oil reservoir to catch the hydraulic oil as it drains.
3. Remove the worm clamp and plug (Figure 65) from the end of the hydraulic oil drain hose and allow the hydraulic oil to drain completely from the reservoir.
4. Replace the worm clamp and plug when finished.

BATTERY/CHARGING SYSTEM

1. Check and clean the battery terminals for corrosion.
2. Disconnect the negative (-) battery terminal during storage. If the unit will be stored where the ambient temperature will drop to -15°C or less, remove and store the battery in a warm, dry place.
3. Check the manufacturer's recommendations for maintaining and charging the battery.

NOTICE

NEVER attempt to charge a battery that is frozen. **The battery can explode** unless first allowed to thaw.

CLEANUP

NEVER allow concrete to harden on the trowel. Wash any concrete off the trowel with water immediately after use. Be careful to not spray a hot engine or muffler. An old paint brush or broom may help loosen any concrete that has started to harden.

TROWEL LUBRICATION

Regular lubrication is required to maintain your trowel in optimal working condition. Schedule maintenance lubrication according to Table 10 below.

Table 10. Trowel Lubrication Schedule		
Location	# of Shots	Interval
Spiders	1 to 1½	Every day
Thrust Collars	1	Every day

Spiders (Daily)

Perform the following lubrication procedure after **every 8 hours of operation**.

1. Locate one of the Zerk grease fittings on either spider assembly (Figure 66). Remove the Zerk fitting cap and set it aside.

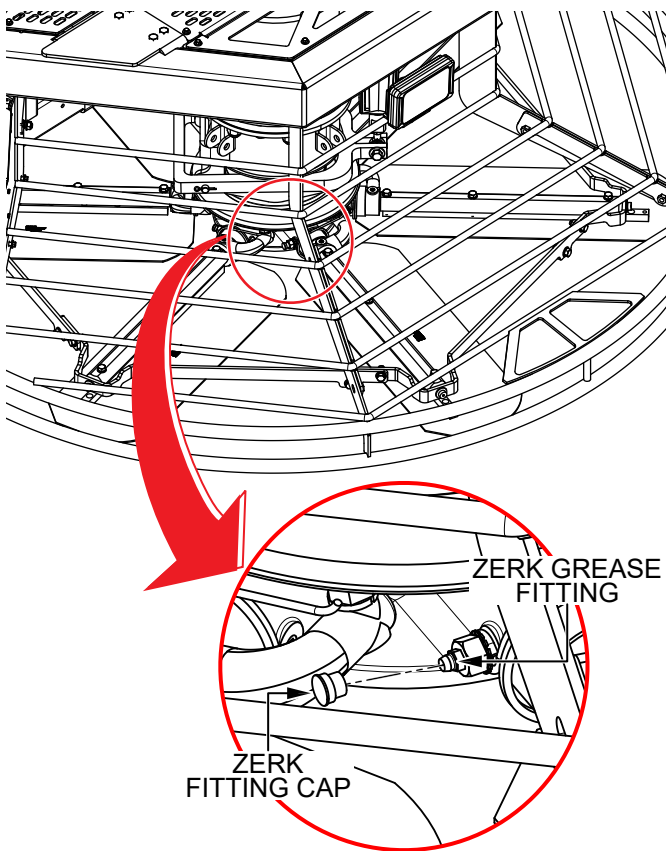

Figure 66. Spider Lubrication

2. Wipe the Zerk grease fitting clean to prevent abrasive material from entering the fitting during lubrication.

3. Lubricate the Zerk grease fitting with 1–1½ shots of multipurpose grade grease. Replace the Zerk grease fitting cap when finished.
4. Repeat steps 1–3 for the remaining grease fittings on both spider assemblies.

Thrust Collars (Daily)

Perform the following lubrication procedure after **every 8 hours of operation**.

1. Locate the Zerk grease fitting on either thrust collar (Figure 67). Remove the Zerk grease fitting cap and set it aside.

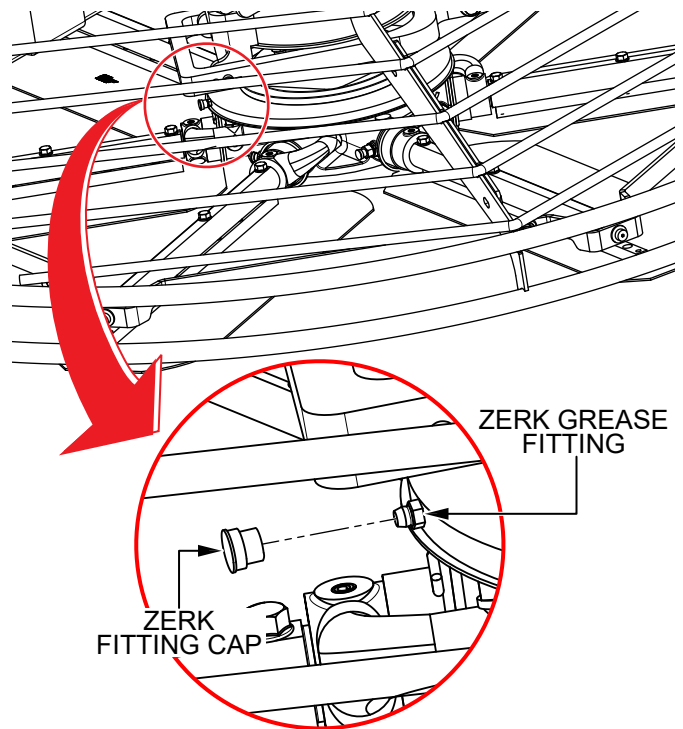

Figure 67. Thrust Collar Lubrication

2. Wipe the Zerk grease fitting clean to prevent abrasive material from entering the fitting during lubrication.
3. Lubricate the Zerk grease fitting with one shot of multipurpose grade grease. Replace the Zerk grease fitting cap when finished.
4. Repeat steps 1–3 for the grease fitting on the remaining thrust collar.

CHANGING BLADES

It is recommended to change **ALL** of the trowel blades at the same time. If only one or some of the blades are changed, the machine will not finish consistently and the machine may wobble or bounce.

1. Place the machine on a flat, level surface. Pitch the blades as flat as possible using the blade pitch controls. Note the blade orientation on the trowel arms. This is important for ride-on trowels as the two sets of blades counter-rotate. Lift the trowel up and place blocks under the main guard rings to support it.
2. Remove the bolts and lock washers on a trowel arm, then remove the blade.
3. Scrape all concrete and debris from the trowel arm to allow proper seating of the new blade.
4. Install the new blade, maintaining the proper blade orientation as noted earlier.
5. Reinstall the bolts and lock washers.
6. Repeat steps 2–5 on all remaining trowel arms.

BLADE PITCH ADJUSTMENT

Maintenance adjustment of blade pitch is made by adjusting a bolt on the trowel arm lever (Figure 68). This bolt is the contact point of the trowel arm with the lower wear plate on the thrust collar.

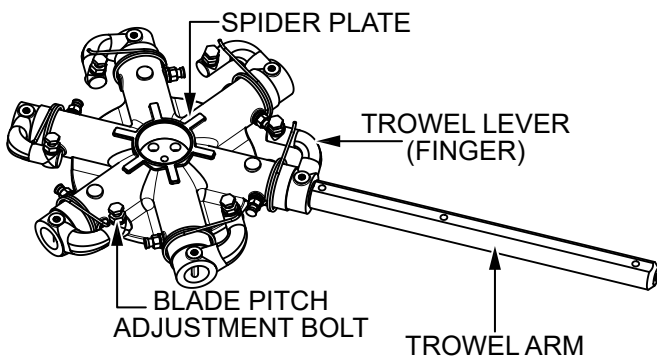

Figure 68. Blade Pitch Adjustment Bolt

The goal of adjustment is to promote consistent blade pitch and finishing quality. If blades are wearing unevenly, look for the following indications that adjustment may be necessary.

- Is one blade completely worn out while the others look new?
- Does the machine have a perceptible rolling or bouncing motion when in use?
- Do the guard rings rock up and down?

The easiest and most consistent way to make adjustments on the trowel arm levers is to use the **trowel arm adjustment tool** (P/N 9177). It comes with all the hardware necessary to perform this adjustment and instructions on how to use the tool.

If a trowel arm adjustment tool is not available and you can see or feel which blade is pulling harder, a temporary field adjustment can be made by adjusting the bolt that corresponds to that blade.

A better way to determine which blades need adjustment is to place the machine on a known **FLAT** surface (e.g. a steel plate) and pitch the blades as flat as possible. Look at the adjustment bolts. They should all barely make contact with the lower wear plate on the spider. If you can see that one of them is not making contact, some adjustment will be necessary.

Adjust the 'high' bolts that are touching the wear plate down to the level of the one that is not touching, or adjust the 'low' bolt up to the level of the higher ones. If possible, adjust the low bolt up to the level of the rest of the bolts. This is the fastest way, but may not always work. Verify that the blades pitch correctly after adjustment.

Blades that are incorrectly adjusted often will not be able to pitch flat. This can occur if the adjusting bolts are raised too high. Conversely, adjusting bolts that are too low will not allow the blades to be pitched high enough for finishing operations.

If the machine is still finishing poorly after blade pitch adjustment has been made, check the trowel blades, arms, and arm bushings for adjustment, wear, or damage.

NOTICE

After any blade adjustment, the pitch system should be recalibrated with the Whiteman Service Tool.

SPIDER PLATE ALIGNMENT

A clean, level area to test the trowel prior to and after trowel arm adjustment is essential. Any uneven spots in the floor or debris under the trowel will give an incorrect perception of alignment. A 3/4-inch-thick, flat steel plate is ideal for testing.

1. Place the trowel in a clean, level test area.
2. Pitch the blades as flat as possible. The adjustment bolts should all barely make contact with the lower wear plate on the spider. Figure 69 illustrates the correct alignment for a spider plate as shipped from the factory.

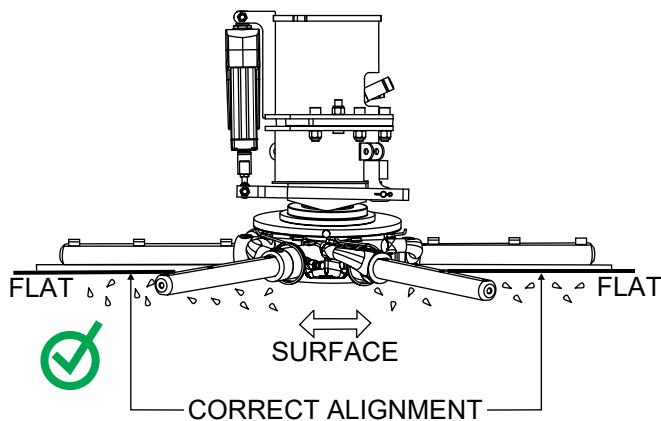

Figure 69. Correct Spider Plate Alignment

3. If any adjustment bolts are not making contact with the lower wear plate, adjustment will be necessary. Figure 70 illustrates incorrect alignment, worn spider bushings, or bent trowel arms.

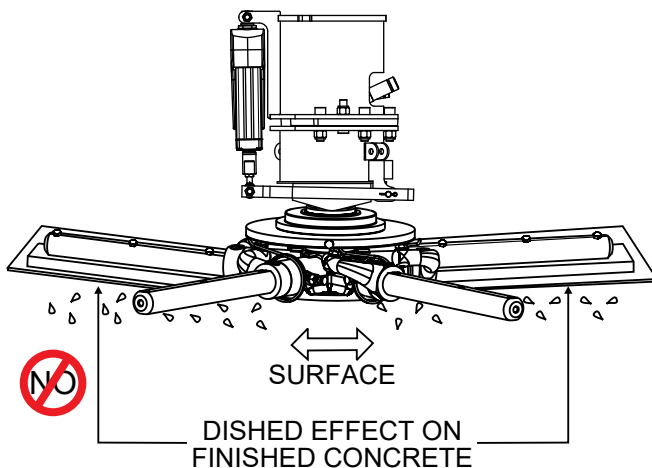

Figure 70. Incorrect Spider Plate Alignment

SPIDER BOLT REPLACEMENT

Existing bolts on both spider assemblies may self loosen due to normal material yield. Replace the left- and right-side spider assembly socket-head bolts (5 per side) and hardened washers (1 per side) every 100 hours of operation.

Preparation

1. Disconnect the negative (**BLACK**) battery cable from the negative (-) terminal on the battery.
2. Lift the trowel as shown in the *Lifting and Transporting* section.
3. Place the trowel on heavy-duty jack stands (Figure 71) on secure, level ground in an area that is free of dirt and debris.

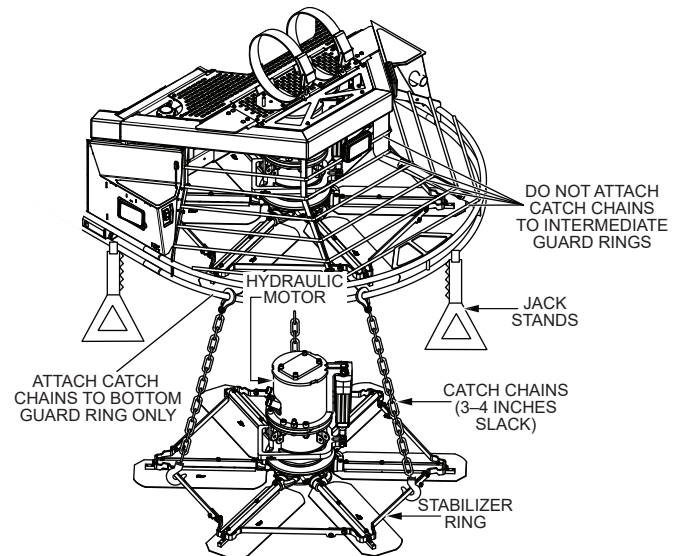

Figure 71. Prepare Trowel

CAUTION

The bolt removal process may result in the sudden separation of the spider assembly from the hydraulic motor shaft. The use of catch chains is recommended to prevent the spider assembly from falling and striking personnel, causing bodily harm.

4. Attach one end of three equally spaced straps or catch chains to the stabilizer ring (Figure 71). Attach the other end of these straps or chains to the **bottom guard ring** in a manner that would prevent the spider assembly from falling.

CAUTION

DO NOT use the intermediate guard rings to support the spider assembly.

NOTICE

Make sure the catch chains are positioned so that they are equally spaced, with **no more than 3 to 4 inches of slack**. The catch chains in Figure 71 appear longer than actual size. They are shown this way for clarity only.

Procedure

1. Remove the left-side spider hub cap plug (Figure 72) and set it aside.

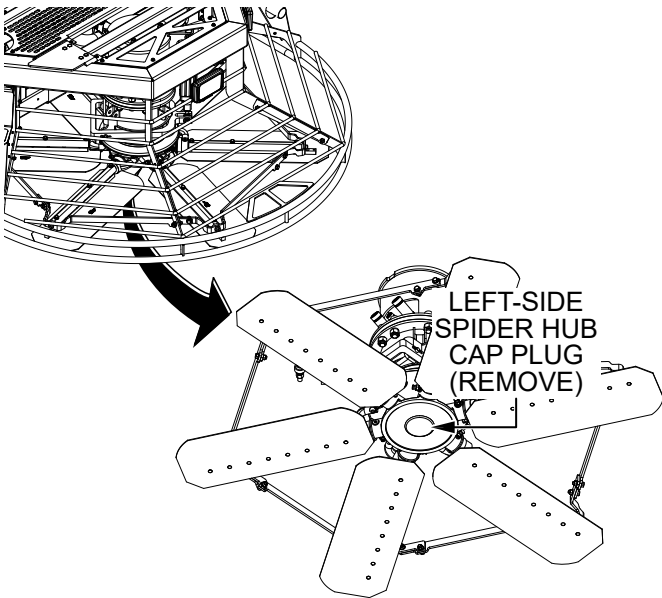

Figure 72. Remove Left-Side Spider Hub Cap Plug

2. Remove and discard the five existing M12-1.75 x 30 mm SHC bolts (Figure 73) securing the left-side spider assembly to the bottom of the left-side hydraulic motor.

NOTICE

DO NOT remove the center retaining bolt (hex flange type) from the spider assembly. Only the 5 surrounding screws (with socket head caps) are to be replaced.

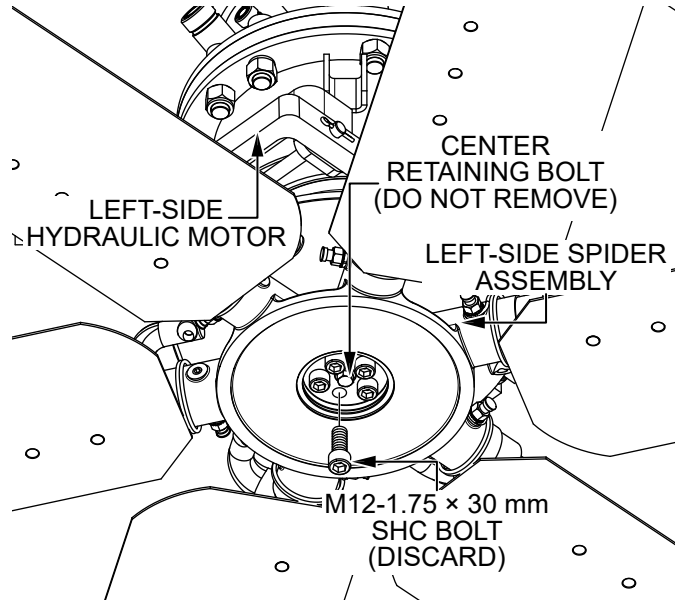

Figure 73. Remove Left-Side Spider Bolts

3. Using an M12 x 1.75 tap, recut the threads of the empty bolt holes to remove any Loctite residue.
4. Use brake cleaner (Figure 74A) to clean out any debris from the empty bolt holes. When finished, use compressed air (Figure 74B) to remove any remaining residue.

NOTICE

Make sure the bolt holes are **clean and completely dry** before installing the new bolts.

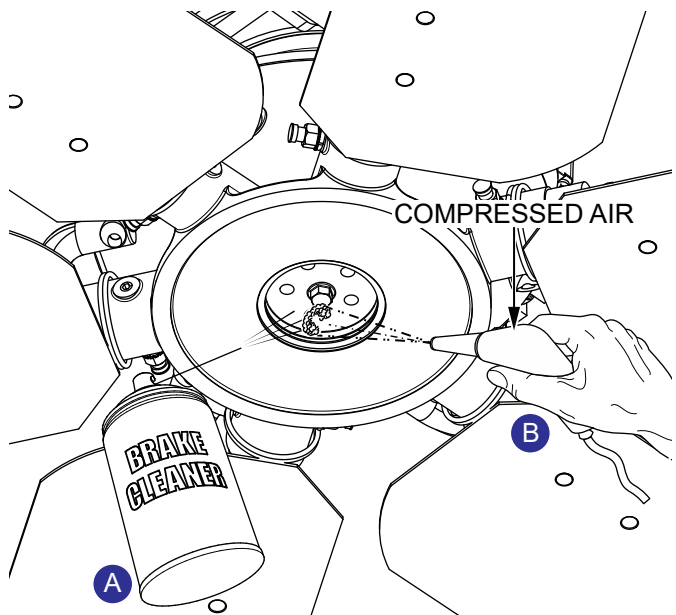

Figure 74. Clean Bolt Holes

- Apply Loctite Blue 242 to the threads on five new M12-1.75 x 30 mm SHC bolts. See Figure 75.

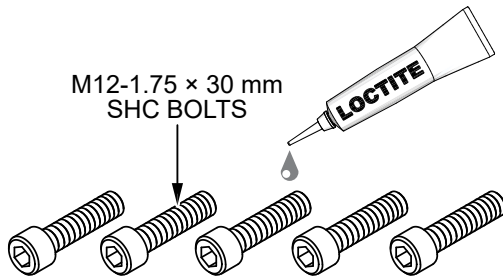

Figure 75. Apply Loctite 242 to New Bolts

- Install five new M12-1.75 x 30 mm SHC bolts with one washer as shown in Figure 76. Torque the bolts in a star pattern to 40 lbf-ft.

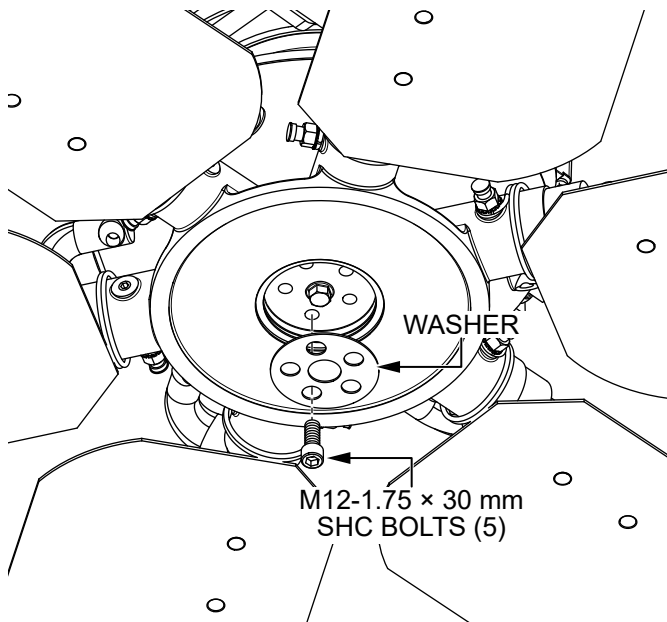

Figure 76. Install New Bolts and Washer

- Re-torque all five M12-1.75 x 30 mm SHC bolts to 90 lbf-ft in a star pattern.
- Reinstall the left-side spider hub cap plug.
- Repeat steps 1–8 on the right-side spider assembly.
- Reconnect the negative (**BLACK**) battery cable to the negative (–) terminal on the battery.

SPIDER REMOVAL

To fully remove a spider assembly from the hydraulic motor shaft:

- Perform steps 1–4 of the **Preparation** section of the **Spider Bolt Replacement** procedure.
- Remove the spider hub cap plug (Figure 77) and set it aside.

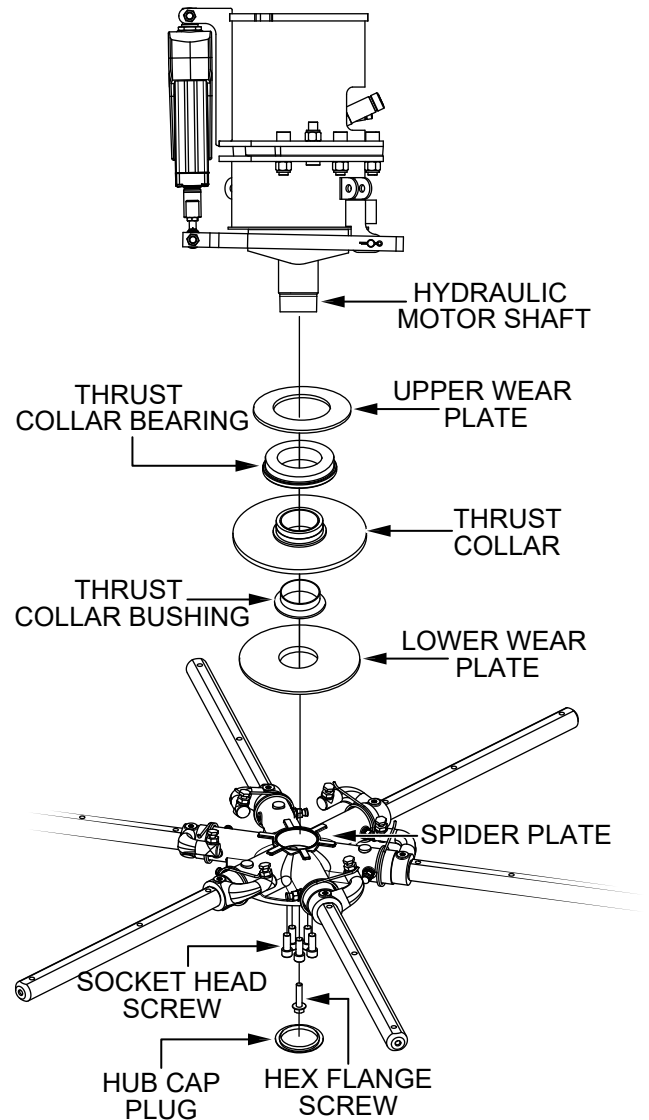

Figure 77. Spider Assembly Components

- Remove and set aside the single hex flange screw and five socket head bolts securing the spider assembly to the hydraulic motor shaft (Figure 77).

4. When reassembling:
 - a. Apply Loctite Blue 242 thread sealant to the spider retaining screw and torque to 150 lbf-ft. (203 N·m).
 - b. Apply Loctite Blue 242 thread sealant to the five socket head bolts and torque the bolts in a star pattern to 40 lbf-ft.
 - c. Re-torque all five socket head bolts in a star pattern to 90 lbf-ft.

Trowel Blade Removal

Remove the three hex head bolts securing the trowel blades to the trowel arms (Figure 78). Set the blades and bolts aside.

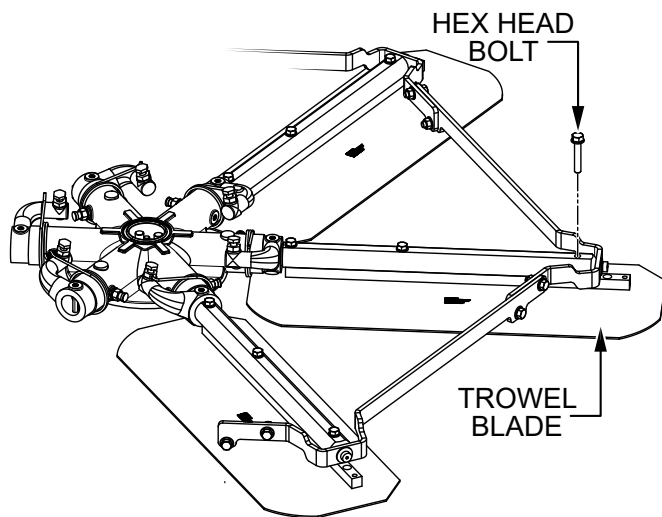

Figure 78. Blade Removal

Trowel Arm Removal

1. Remove the hardware securing the stabilizer struts to the trowel arms (Figure 79). Set the struts and hardware aside.

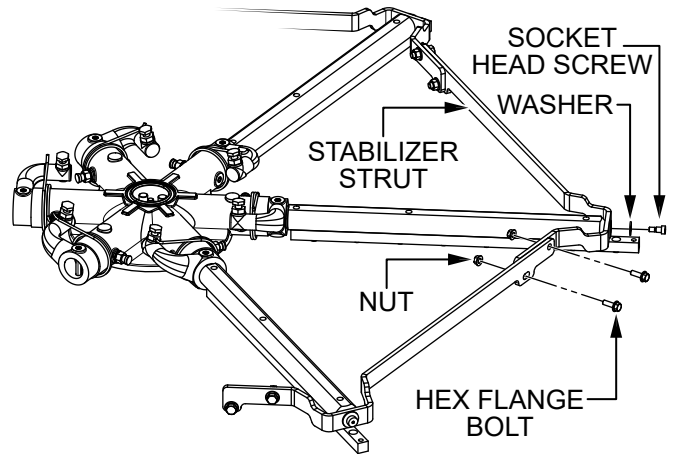

Figure 79. Stabilizer Ring Removal

2. Each trowel arm is held in place at the spider plate by a hex head bolt (Zerk grease fitting). Remove the hex head bolt (Figure 80) from the spider plate.

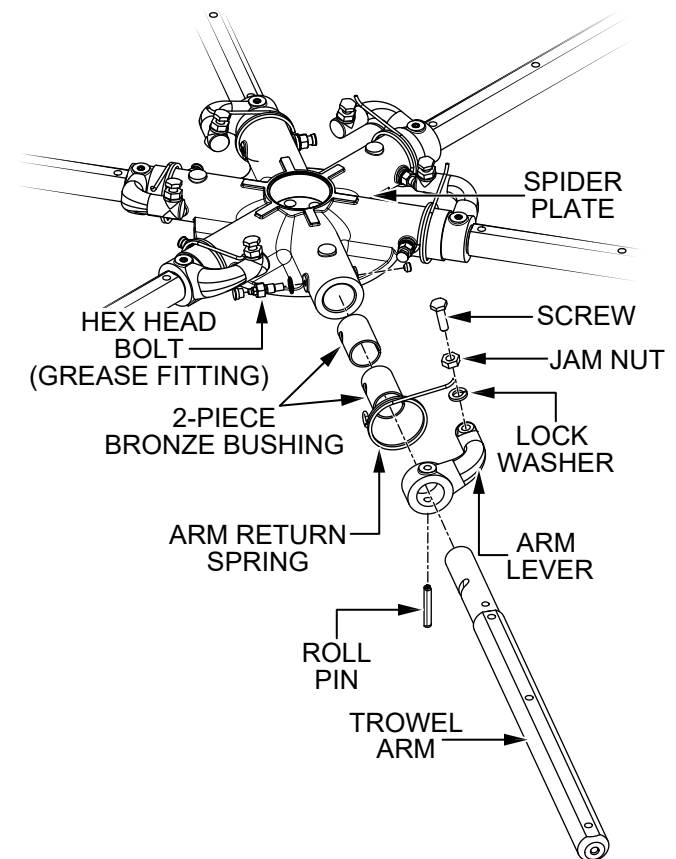

Figure 80. Trowel Arm Removal

3. Remove the trowel arm (Figure 80) from the spider plate.

4. Should the trowel arm insert (bronze bushing) come out with the trowel arm, remove the bushing from the trowel arm and set it aside. If the bushing is retained inside the spider plate, carefully remove the bushing.
5. Examine the bronze trowel arm bushings (Figure 81), and clean them if necessary. Replace the bushings if they are worn or out-of-round.

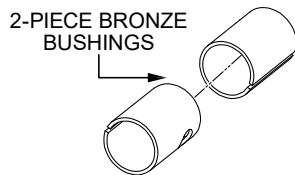

Figure 81. Bronze Bushings

6. Wire brush any buildup of concrete from all six sides of the trowel arm.
7. Repeat steps 2–6 for the remaining trowel arms.

Checking Trowel Arm Straightness

Trowel arms can be damaged by rough handling such as dropping the trowel on a pad or by striking exposed plumbing, forms or rebar while in operation. A bent trowel arm will prevent smooth, fluid rotation of the blades. If bent trowel arms are suspected, examine them for straightness as follows:

1. Place the trowel arm onto a thick steel plate, granite slab, or any other surface which is flat and true (Figure 82).

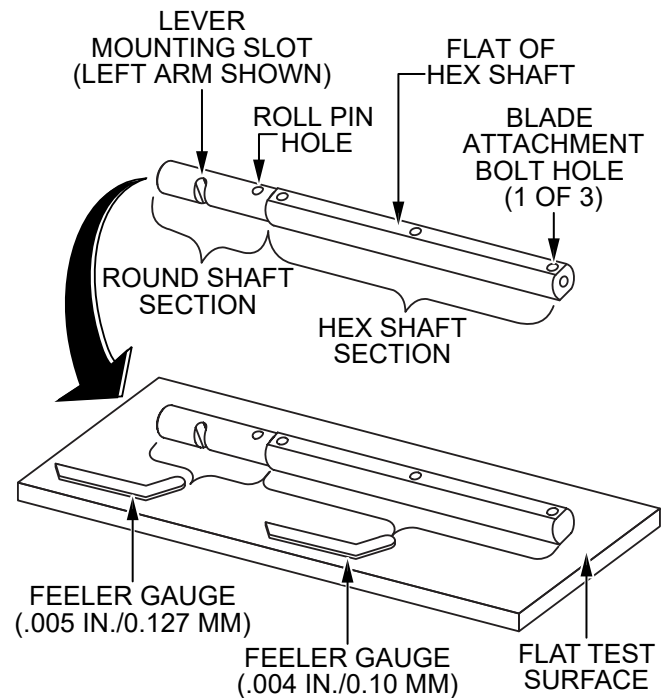

Figure 82. Checking Trowel Arm Straightness

2. Check each of the six sides of the trowel arm hex shaft section (Figure 82). A feeler gauge of .004 in. (0.10 mm) should not pass between the flat of the trowel arm and the test surface along its length on the test surface.
3. Check the clearance between the round shaft and the test surface as one of the flat hex sections of the arm rests on the test surface (Figure 82). Rotate the arm to each of the flat hex sections and check the clearance of the round shaft. Use a feeler gauge of .005 in. (0.127 mm). Each section should have the same clearance between the round of the trowel arm shaft and the test surface.
4. Replace the trowel arm if it is bent or uneven.

Trowel Arm Adjustment

Figure 83 illustrates a **trowel arm adjustment tool**. As a trowel arm is locked into the adjustment tool, the trowel arm bolt is adjusted to where it contacts a stop on the fixture. This will consistently adjust all of the trowel arms, keeping the finisher as flat and evenly pitched as possible.

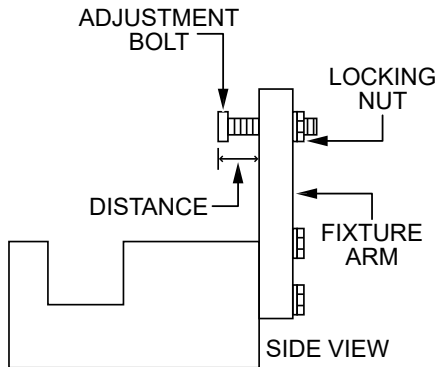

Figure 83. Trowel Arm Adjustment Tool (Side View)

1. Locate a trowel arm adjustment tool (P/N 9177).
2. Place the fixture arm in the correct position (up or down) for the trowel arm's direction of rotation. For trowel arms that rotate **clockwise**, place the fixture arm in the **UP** position (Figure 84A). For trowel arms that rotate **counterclockwise**, place the fixture arm in the **DOWN** position (Figure 84B).

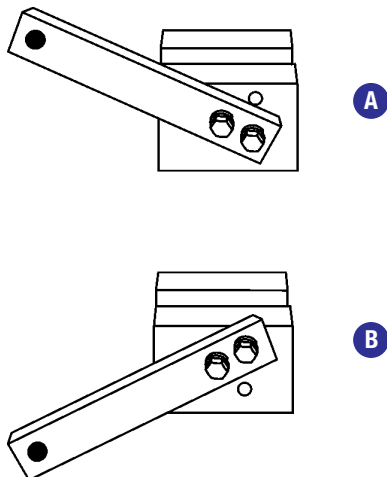

Figure 84. Fixture Arm Position

3. Adjust the fixture adjustment bolt distance shown in Figure 83 to 0.15 in. (3.81 mm).

4. Unscrew the locking bolts on the adjustment tool and place the trowel arm into the fixture channel as shown in Figure 85. A thin shim may be required to cover the blade holes on the trowel arm. Make sure to align the trowel arm adjustment bolt with the fixture adjustment bolt.

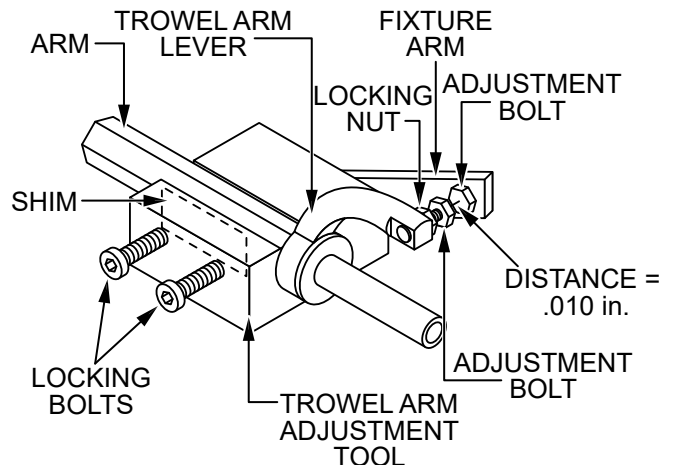

Figure 85. Trowel Arm Adjustment

5. Tighten the locking bolts (Figure 85) with an Allen wrench to secure the trowel arm in place.
6. Loosen the locking nut on the trowel arm lever (Figure 85), then turn the trowel arm adjustment bolt until it barely touches (.010") the fixture adjustment bolt.
7. Once the adjustment has been made, tighten the locking nut on the trowel arm lever to lock it in place.
8. Loosen the locking bolts and remove the trowel arm.
9. Repeat steps 2–8 for the remaining trowel arms.
10. Recalibrate pitch with the Whiteman Service Tool.

Reassembly

1. Clean and examine the entire spider assembly including the upper and lower wear plates and thrust collar. Wire brush any concrete or rust buildup. Replace any spider components that are damaged or out-of-round.
2. Make sure the bronze trowel arm bushings are not damaged or out-of-round. Clean the bushings if necessary. Replace any bronze bushing that is damaged or worn.
3. Reinstall the bronze bushings onto the trowel arm.
4. Repeat steps 2–3 for each trowel arm.

5. Make sure that the spring tensioner is in the correct position to exert tension on the trowel arm.
6. Insert all trowel arms with levers (with bronze bushings already installed) into the spider plate, using care to align the grease holes on the bronze bushings with the grease hole fittings on the spider plate.
7. Lock the trowel arms in place by tightening the hex head bolts with Zerk grease fittings and jam nuts.
8. Reinstall the blades onto the trowel arms.
9. Reinstall the stabilizer struts onto the spider assembly.
10. Lubricate all grease points (Zerk fittings) with premium Lithium 12-based grease, conforming to NLG1 Grade #2 consistency.

FLOAT PAN INSTALLATION

Float pans attach to the trowel arms and allow early floating on wet concrete and easy movement from wet to dry areas. They are also very effective at embedding large aggregates and surface hardeners. There are two methods for installing pans: Z-clips or latch pins.

WARNING

ALWAYS install float pans either in the work area or in an area that is next to and level with the work area.

NEVER lift the trowel with float pans attached.

NOTICE

The rotors must be turned in order to install and secure float pans to the trowel blades. Rotors are only turned via drive bypass switch and foot pedal engagement. **DO NOT** engage the seat switch by sitting in the operator's seat.

Installing Float Pans with Z-Clips

1. Press and hold the **panning mode button** (Figure 86) for 3 seconds to activate panning mode. The trowel blades will be pitched flat and the pitch systems retracted to allow for the use of float pans.

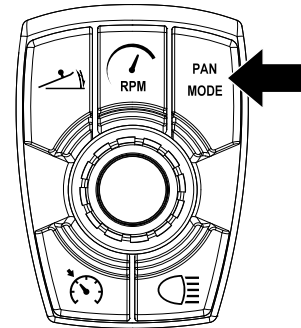

Figure 86. Panning Mode Button

2. Lift the trowel just enough to slide float pans with Z-clips under the blades (Figure 87). Slowly lower the trowel onto the pans with the blades adjacent to the Z-clips.

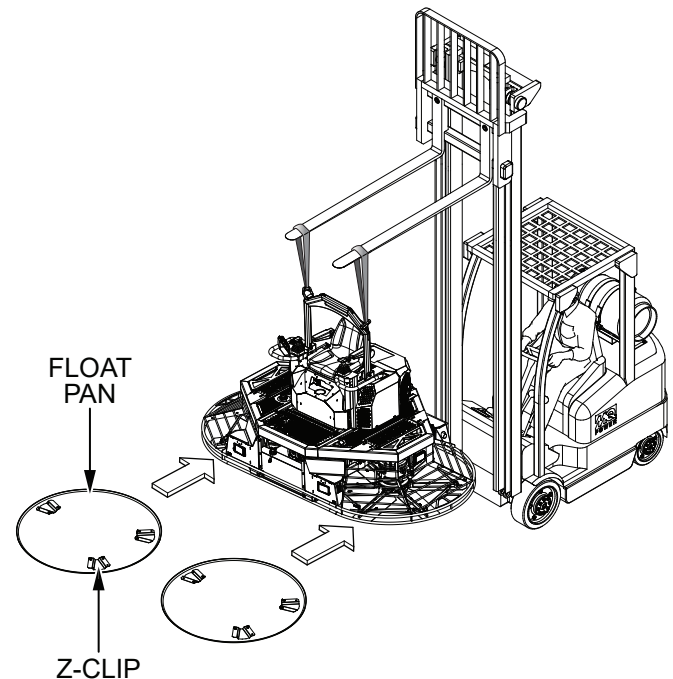

Figure 87. Float Pan Positioning

3. Rotate the blades into position under the Z-clips (Figure 88). Make sure the blades are rotated in the same direction as when the machine is in operation, or use the engine to rotate the blades into position.

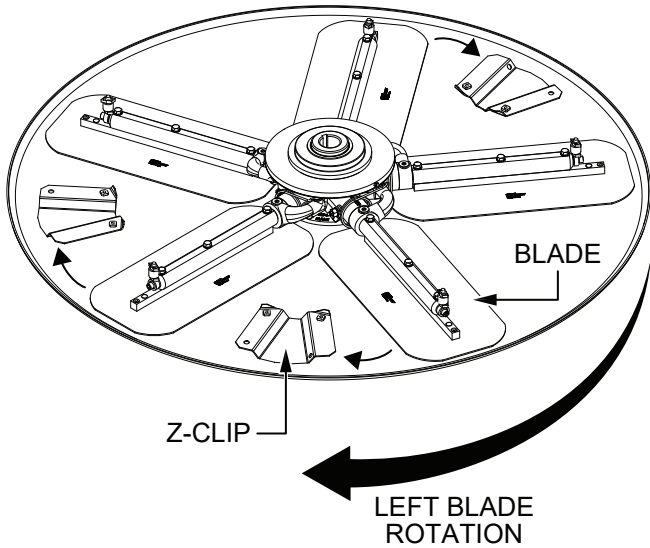

Figure 88. Blade Rotation

4. Attach the blade tie-downs to the far side of the Z-clips using the tie-down knobs as shown in Figure 89.

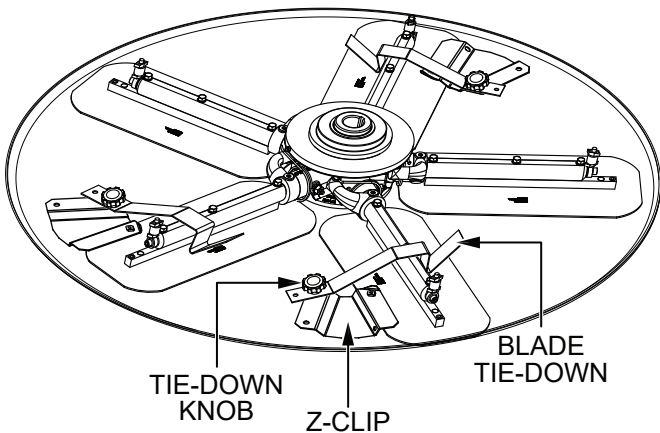

Figure 89. Float Pan Installation (Z-Clips)

5. Make sure the blade edges are secured under the Z-clips and the tie-downs are secured completely over the edges of the blade bar before the machine is put back into operation.

Installing Float Pans with Latch Pins

1. Press and hold the **panning mode button** (Figure 86) for 3 seconds to activate panning mode. The trowel blades will be pitched flat and the pitch systems retracted to allow for the use of float pans.
2. Lift the trowel just enough to slide a float pan under the blades. Lower the finisher onto the pan with the blades between the blade stops (Figure 90).

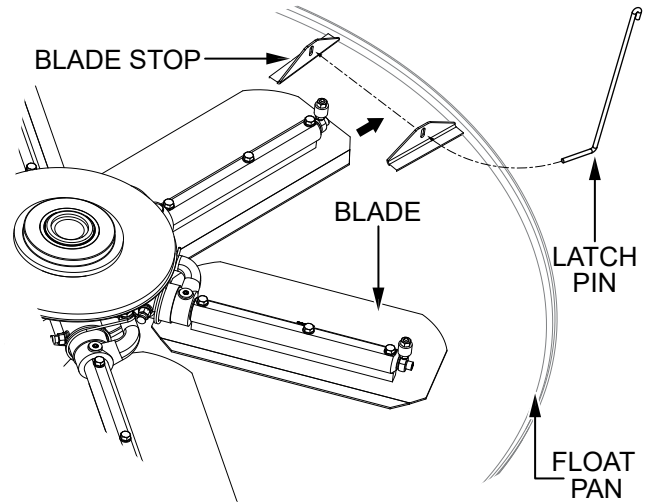

Figure 90. Float Pan Installation (Latch Pins)

3. Route a latch pin through the holes in the blade stops as shown in Figure 90.
4. After it has been routed through the blade stop holes, rotate the latch pin so the end that is bent approximately 90 degrees lays flat on the surface of the float pan. See Figure 91.

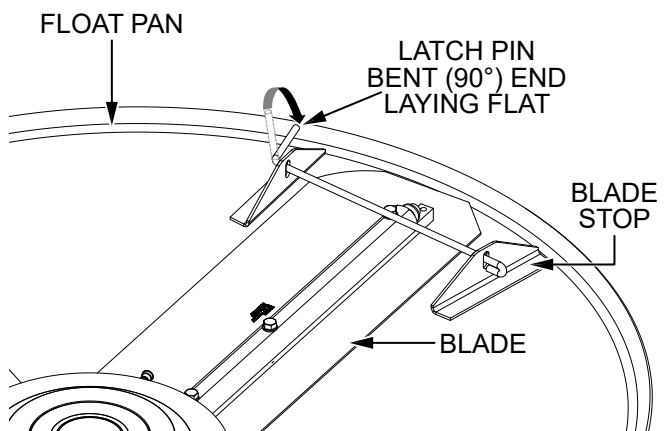

Figure 91. Latch Pin Placement

5. Make sure the blade edges are secured between the blade stops, and the latch pin is secured completely over the blade, locking it in place.
6. To finish installing the float pan onto the remaining finisher blades, turn the rotors by pressing and holding the left or right drive bypass switch (Figure 92) and the foot pedal.

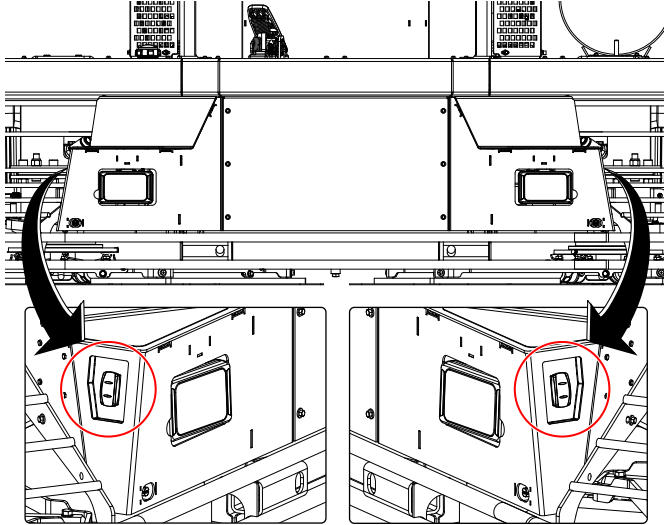

Figure 92. Drive Bypass Switches

NOTICE

A second person may be needed to help turn the rotors by hand and to secure the latch pins in the blade stops.

7. Repeat steps 3–5 for the remaining finisher blades.
8. Make sure the float pans are well secured to the blades before the trowel is put back into operation.
9. Periodically check the latch pins during normal operation to ensure they are still in the correct position.

PREPARATION FOR LONG-TERM STORAGE

1. Disconnect and remove the battery.
2. Drain all fuel from the fuel tank.
3. Clean the trowel exterior with a cloth soaked in clean oil.
4. Cover the trowel with a plastic sheet and store it out of direct sunlight in a moisture- and dust-free location.

TROWEL DECOMMISSIONING

Decommissioning is a controlled process used to safely retire a piece of equipment that is no longer serviceable. If the equipment poses an unacceptable and unreparable safety risk due to wear or damage, or is no longer cost effective to maintain (beyond life-cycle reliability), and is to be decommissioned (demolition and dismantlement), the following procedure must be performed:

1. Drain all fluids completely. These may include oil, gasoline, hydraulic oil, and antifreeze. Dispose of all fluids properly in accordance with local and governmental regulations. **NEVER** pour fluids on the ground or down drains or sewers.
2. Remove the battery and bring it to an appropriate facility for lead reclamation. Use safety precautions when handling batteries that contain sulfuric acid.
3. The remainder can be brought to a salvage yard or metal reclamation facility for further dismantling.

TROUBLESHOOTING

THERMAL MANAGEMENT MODE

Thermal Management mode is designed to reduce blade speed if the engine coolant or hydraulic fluid reaches a higher-than-normal temperature. The trowel will slowly reduce blade speed until the temperature is stabilized.

Thermal Management mode monitors the engine coolant temperature and both the left- and right-side hydraulic cooler temperatures. If any of these three temperature readings exceeds a preset limit (Table 11), the system will start reducing machine load by gradually slowing blade speed.

Table 11. Thermal Management Mode Temperature Limits	
Temperature	°F (°C)
Engine Coolant	217 (103)
Inlet (Right) Hydraulic Cooler	200 (93)
Outlet (Left) Hydraulic Cooler	175 (79)

Operator Interface

While Thermal Management is actively reducing blade speed, the operator will not be able to increase blade speed using the maximum rotor speed setting control knob. The operator can manually reduce blade speed while Thermal Management is active.

As the system cools below the preset limits, blade speed will gradually return to the operator's preset maximum rotor speed setting.

Digital Display Messages

When Thermal Management mode is enabled, the operator will be notified on the digital display (Figure 93).

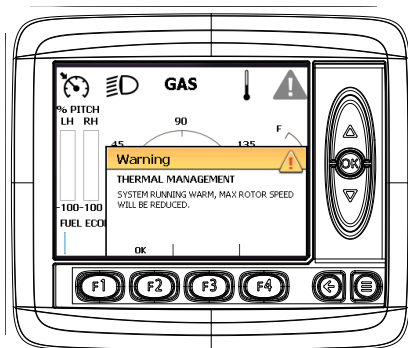

Figure 93. Thermal Management Mode (Warning)

The operator may also see fault messages relating to the high temperatures as shown in Figure 94.

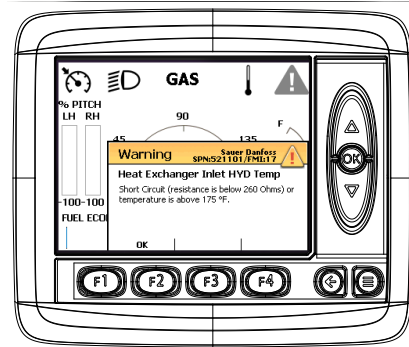

Figure 94. Thermal Management Mode (Fault)

After clearing the warning and fault messages, the operator will be notified that Thermal Management is actively slowing blade speed. A red, blinking **THERM MGMT** message (Figure 95) will appear at the bottom center of the main digital display screen.

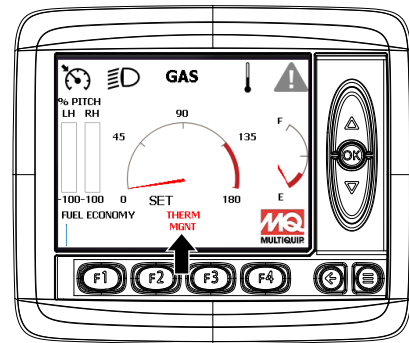

Figure 95. Thermal Management Mode (Active)

Once the system has sufficiently cooled and blade speed has returned to normal, the red, blinking **THERM MGMT** message will disappear, indicating that Thermal Management mode has been disabled.

TROUBLESHOOTING

FAULTS

The STXDF is equipped with a digital control panel and display that communicates with the trowel Engine Control Unit (ECU) and Machine Control Unit (MCU) using the SAE J1939 Controller Area Network (CAN) bus protocol. The Engine Control Unit (ECU) diagnoses engine faults and the Machine Control Unit (MCU) diagnoses machine faults.

If the fault icon on the digital display turns **AMBER** (Figure 96), shut down the trowel and correct the problem as soon as possible.

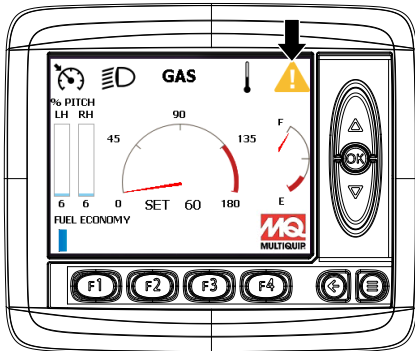

Figure 96. Fault Icon (AMBER)

If the fault icon on the digital display turns **RED** (Figure 97), shut down the trowel **immediately** and correct the problem.

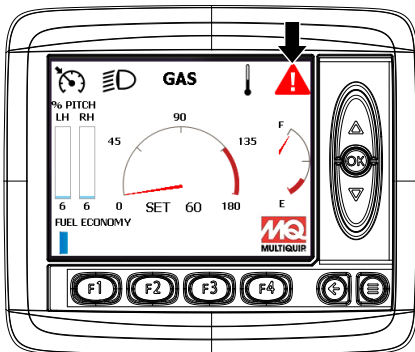

Figure 97. Fault Icon (RED)

Engine and machine faults can be viewed on the **Active Fault screens** of the digital display by pressing the **F1 button** (Figure 98). See Table 12–Table 20 for a list of active fault codes and countermeasures.

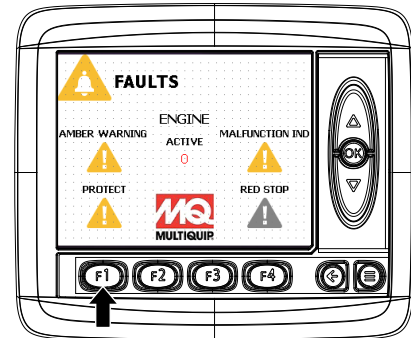

Figure 98. Fault Menu Button (F1)

TROUBLESHOOTING

Table 12. Engine Fault Codes

Fault Index	Description	SPN	FMI
0	DTC 108: MAP pressure high	106	16
1	DTC 107: MAP voltage low	106	4
2	DTC 118: ECT voltage high	110	3
3	DTC 117: ECT voltage low	110	4
4	DTC 116: ECT higher than expected stage 1	110	15
5	DTC 113: IAT voltage high	105	3
6	DTC 112: IAT voltage low	105	4
7	DTC 2229: BP pressure high	108	0
8	DTC 129: BP pressure low	108	1
9	DTC 563: Vbat voltage high	168	15
10	DTC 562: Vbat voltage low	168	17
11	DTC 643: Sensor supply voltage 1 high	1079	3
12	DTC 642: Sensor supply voltage 1 low	1079	4
13	DTC 123: TPS1 voltage high	51	3
14	DTC 122: TPS1 voltage low	51	4
15	DTC 223: TPS2 voltage high	3673	3
16	DTC 222: TPS2 voltage low	3673	4
17	DTC 221: TPS1-2 higher than expected	51	0
18	DTC 121: TPS1-2 lower than expected	51	1
19	DTC 2122: FPP1 voltage high	91	3
20	DTC 2123: FPP1 voltage low	91	4
21	DTC 2128: FPP2 voltage high	29	3
22	DTC 2127: FPP2 voltage low	29	4
23	DTC 2115: FPP1 higher than IVS	91	0
24	DTC 2139: FPP1 lower than IVS	91	1
25	DTC 2116: FPP2 higher than IVS	29	0
26	DTC 2140: FPP2 lower than IVS	29	1
27	DTC 2126: FPP1-2 higher than expected	91	16
28	DTC 2121: FPP1-2 lower than expected	91	18
29	DTC 524: Oil pressure low	100	1
30	DTC 171: Adaptive-learn gasoline bank1 high	4237	0
31	DTC 172: Adaptive-learn gasoline bank1 low	4237	1
32	DTC 1155: Closed-loop gasoline bank1 high	4236	0
33	DTC 1156: Closed-loop gasoline bank1 low	4236	1
34	DTC 1157: Closed-loop gasoline bank2 high	4238	0
35	DTC 1158: Closed-loop gasoline bank2 low	4238	1
36	DTC 1151: Closed-loop LPG high	4236	0
37	DTC 1152: Closed-loop LPG low	4236	1

TROUBLESHOOTING

Table 13. Engine Fault Codes (Continued)

Fault Index	Description	SPN	FMI
38	DTC 1153: Closed-loop NG high	4236	0
39	DTC 1154: Closed-loop NG low	4236	1
40	DTC 174: Adaptive-learn gasoline bank2 high	4239	0
41	DTC 175: Adaptive-learn gasoline bank2 low	4239	1
42	DTC 1161: Adaptive-learn LPG high	4237	0
43	DTC 1162: Adaptive-learn LPG low	4237	1
44	DTC 1163: Adaptive-learn NG high	4237	0
45	DTC 1164: Adaptive-learn NG low	4237	1
46	DTC 261: Injector 1 open or short to ground	651	5
47	DTC 264: Injector 2 open or short to ground	652	5
48	DTC 267: Injector 3 open or short to ground	653	5
49	DTC 270: Injector 4 open or short to ground	654	5
50	DTC 273: Injector 5 open or short to ground	655	5
51	DTC 276: Injector 6 open or short to ground	656	5
52	DTC 279: Injector 7 open or short to ground	657	5
53	DTC 282: Injector 8 open or short to ground	658	5
54	DTC 285: Injector 9 open or short to ground	659	5
55	DTC 288: Injector 10 open or short to ground	660	5
56	DTC 262: Injector 1 coil shorted	651	6
57	DTC 265: Injector 2 coil shorted	652	6
58	DTC 268: Injector 3 coil shorted	653	6
59	DTC 271: Injector 4 coil shorted	654	6
60	DTC 274: Injector 5 coil shorted	655	6
61	DTC 277: Injector 6 coil shorted	656	6
62	DTC 280: Injector 7 coil shorted	657	6
63	DTC 283: Injector 8 coil shorted	658	6
64	DTC 286: Injector 9 coil shorted	659	6
65	DTC 289: Injector 10 coil shorted	660	6
86	DTC 217: ECT higher than expected stage 2	110	0
87	DTC 111: IAT higher than expected stage 1	105	15
88	DTC 127: IAT higher than expected stage 2	105	0
89	DTC 327: Knock1 sensor open or not present	731	4
90	DTC 2112: Unable to reach higher TPS	51	7
91	DTC 2111: Unable to reach lower TPS	51	7
92	DTC 1531: Gov1/2/3 interlock failure	0	31
93	DTC 628: Fuel-pump high-side open or short to ground	1347	5
94	DTC 629: Fuel-pump high-side short to power	1347	6
95	DTC 342: Loss of CAM input signal	723	4

TROUBLESHOOTING

Table 14. Engine Fault Codes (Continued)

Fault Index	Description	SPN	FMI
96	DTC 341: CAM input signal noise	723	2
97	DTC 336: CRANK input signal noise	636	2
98	DTC 16: Crank and/or cam could not synchronize during start	636	8
99	DTC 606: Microprocessor failure - COP	629	31
100	DTC 1612: Microprocessor failure - RTI 1	629	31
101	DTC 1613: Microprocessor failure - RTI 2	629	31
102	DTC 1614: Microprocessor failure - RTI 3	629	31
103	DTC 1615: Microprocessor failure - A/D	629	31
104	DTC 1616: Microprocessor failure - Interrupt	629	31
105	DTC 601: Microprocessor failure - FLASH	628	13
106	DTC 604: Microprocessor failure - RAM	630	12
107	DTC 326: Knock1 excessive or erratic signal	731	2
108	DTC 219: RPM higher than max allowed govern speed	515	15
109	DTC 1111: RPM above fuel rev limit level	515	16
110	DTC 1112: RPM above spark rev limit level	515	0
111	DTC 134: EGO1 open / lazy	3217	5
112	DTC 154: EGO2 open / lazy	3227	5
113	DTC 140: EGO3 open / lazy	3256	5
114	DTC 1521: CHT higher than expected stage 1	110	16
115	DTC 1522: CHT higher than expected stage 2	110	0
116	DTC 1515: AUX analog Pull-Down 1 high voltage	710	3
117	DTC 1516: AUX analog Pull-Down 1 low voltage	710	4
118	DTC 1511: AUX analog Pull-Up 1 high voltage	701	3
119	DTC 1512: AUX analog Pull-Up 1 low voltage	701	4
120	DTC 1513: AUX analog Pull-Up 2 high voltage	702	3
121	DTC 1514: AUX analog Pull-Up 2 low voltage	702	4
126	DTC 238: TIP high voltage	102	3
127	DTC 237: TIP low voltage	102	4
128	DTC 92: FP high voltage	94	3
129	DTC 91: FP low voltage	94	4
130	DTC 420: Catalyst inactive on gasoline (Bank 1)	3050	11
131	DTC 1165: Catalyst inactive on LPG	3050	11
132	DTC 1166: Catalyst inactive on NG	3050	11
133	DTC 1171: MegaJector delivery pressure higher than expected	520260	0
134	DTC 1172: MegaJector delivery pressure lower than expected	520260	1
135	DTC 1173: MegaJector comm lost	520260	31
136	DTC 1174: MegaJector voltage supply high	520260	3
137	DTC 1175: MegaJector voltage supply low	520260	4

TROUBLESHOOTING

Table 15. Engine Fault Codes (Continued)

Fault Index	Description	SPN	FMI
138	DTC 1176: MegaJector internal actuator fault detection	520260	12
139	DTC 1177: MegaJector internal circuitry fault detection	520260	12
140	DTC 1178: MegaJector internal comm fault detection	520260	12
141	DTC 1131: WGP voltage high	1192	3
142	DTC 1132: WGP voltage low	1192	4
145	DTC 236: TIP active	102	2
146	DTC 183: FT high voltage	174	3
147	DTC 182: FT low voltage	174	4
152	DTC 337: Crank signal loss	636	4
153	DTC 1625: J1939 shutdown request	1110	31
158	DTC 686: Power relay ground short	1485	4
159	DTC 685: Power relay coil open	1485	5
160	DTC 687: Power relay coil short to power	1485	3
161	DTC 616: Start relay ground short	1321	4
162	DTC 615: Start relay coil open	1321	5
163	DTC 617: Start relay coil short to power	1321	3
167	DTC 628: Fuel pump relay control ground short	1348	4
168	DTC 627: Fuel pump relay coil open	1348	5
169	DTC 629: Fuel pump relay coil short to power	1348	3
170	DTC 1644: MIL control ground short	1213	4
171	DTC 650: MIL open	1213	5
172	DTC 1645: MIL control short to power	1213	3
175	DTC 2130: IVS stuck at-idle, FPP1/2 match	558	5
176	DTC 2131: IVS stuck off-idle, FPP1/2 match	558	6
177	DTC 1121: FPP1/2 simultaneous voltages out-of-range (redundancy lost)	91	31
178	DTC 2120: FPP1 invalid voltage and FPP2 disagrees with IVS (redundancy lost)	520199	11
179	DTC 2125: FPP2 invalid voltage and FPP1 disagrees with IVS (redundancy lost)	520199	11
180	DTC 1122: FPP1/2 do not match each other or IVS (redundancy lost)	520199	11
181	DTC 653: Sensor supply voltage 2 high	1080	3
182	DTC 652: Sensor supply voltage 2 low	1080	4
183	DTC 1611: Sensor supply voltage 1 and 2 out-of-range	1079	31
184	DTC 332: Knock2 sensor open or not present	520197	4
185	DTC 331: Knock2 excessive or erratic signal	520197	2
186	DTC 2135: TPS1/2 simultaneous voltages out-of-range	51	31
187	DTC 2428: EGT temperature high	173	0
188	DTC 1628: J1939 CAN address / engine-number conflict	639	13
189	DTC 1631: PWM1-Gauge1 open / ground short	697	5
190	DTC 1632: PWM1-Gauge1 short to power	697	3

TROUBLESHOOTING

Table 16. Engine Fault Codes (Continued)

Fault Index	Description	SPN	FMI
191	DTC 1633: PWM2-Gauge2 open / ground short	698	5
192	DTC 1634: PWM2-Gauge2 short to power	698	3
193	DTC 1635: PWM3-Gauge3 open / ground short	699	5
194	DTC 1636: PWM3-Gauge3 short to power	699	3
195	DTC 1637: PWM4 open / ground short	700	5
196	DTC 1638: PWM4 short to power	700	3
197	DTC 1639: PWM5 open / ground short	924	5
198	DTC 1640: PWM5 short to power	924	3
199	DTC 430: Catalyst inactive on gasoline (Bank 2)	3051	11
200	DTC 160: EGO4 open / lazy	3266	5
201	DTC 1517: AUX analog Pull-Up 3 high voltage	703	3
202	DTC 1518: AUX analog Pull-Up 3 low voltage	703	4
203	DTC 1541: AUX analog Pull-Up/Down 1 high voltage	704	3
204	DTC 1542: AUX analog Pull-Up/Down 1 low voltage	704	4
205	DTC 1543: AUX analog Pull-Up/Down 2 high voltage	705	3
206	DTC 1544: AUX analog Pull-Up/Down 2 low voltage	705	4
207	DTC 1545: AUX analog Pull-Up/Down 3 high voltage	706	3
208	DTC 1546: AUX analog Pull-Up/Down 3 low voltage	706	4
209	DTC 1551: AUX digital 1 high voltage	707	3
210	DTC 1552: AUX digital 1 low voltage	707	4
211	DTC 1553: AUX digital 2 high voltage	708	3
212	DTC 1554: AUX digital 2 low voltage	708	4
213	DTC 1555: AUX digital 3 high voltage	709	3
214	DTC 1556: AUX digital 3 low voltage	709	4
215	DTC 188: Gaseous fuel temperature sender high voltage	3468	3
216	DTC 187: Gaseous fuel temperature sender low voltage	3468	4
217	DTC 1629: J1939 TSC1 message receipt loss	695	9
218	DTC 359: Fuel run-out longer than expected	632	31
219	DTC 1630: J1939 ETC message receipt loss	91	19
229	DTC 1561: AUX analog Pull-Down 2 high voltage	711	3
230	DTC 1561: AUX analog Pull-Down 2 low voltage	711	4
231	DTC 1561: AUX analog Pull-Down 3 high voltage	712	3
232	DTC 1561: AUX analog Pull-Down 3 low voltage	712	4
275	DTC 1651: J1939 ETC message receipt loss while in-gear	91	9
276	DTC 1661: PWM6 open / ground short	925	5
277	DTC 1662: PWM6 short to power	925	3
278	DTC 1663: PWM7 open / ground short	926	5
279	DTC 1664: PWM7 short to power	926	3

TROUBLESHOOTING

Table 17. Engine Fault Codes (Continued)

Fault Index	Description	SPN	FMI
280	DTC 1547: AUX analog Pull-Up/Down 4 high voltage	713	3
281	DTC 1548: AUX analog Pull-Up/Down 4 low voltage	713	4
283	DTC 1665: PWM8 open / ground short	2646	5
284	DTC 1666: PWM8 short to power	2646	3
285	DTC 1669: PWM9 open / ground short	2647	5
286	DTC 1670: PWM9 short to power	2647	3
287	DTC 1183: MegaJector autozero / lockoff failure	520803	31
288	DTC 11: Intake cam / distributor position error	520800	7
290	DTC 88 Fuel pressure higher than expected	94	0
291	DTC 87 Fuel pressure lower than expected	94	1

TROUBLESHOOTING

Table 18. Machine Fault Codes

Parameter Name	SPN	FMI	Fault Conditions	Fault Reactions
5 Volt Supply	3509	1	Sensor output is < 0.10 V	Red stop lamp is on. Pump stroke is disabled.
		3	Sensor output is < 4.50 V	Red stop lamp is on. Pump stroke is disabled.
Left Hand Hydraulic Loop Temperature	521100	0	Open circuit or short to power: resistance is above 10,000 ohms.	Amber warning lamp and hydraulic cooling fans are on.
		1	Short to ground (resistance is below 60 ohms) or temperature is above 210°F.	Red stop lamp and hydraulic cooling fans are on.
		17	Short circuit (resistance is below 260 ohms) or temperature is above 175°F.	Amber warning lamp and hydraulic cooling fans are on.
Right Hand Hydraulic Loop Temperature	521101	0	Open circuit or short to power: resistance is above 10,000 ohms.	Amber warning lamp and hydraulic cooling fans are on.
		1	Short to ground (resistance is below 60 ohms) or temperature is above 220°F.	Red stop lamp and hydraulic cooling fans are on.
		17	Short circuit (resistance is below 260 ohms) or temperature is above 200°F.	Amber warning lamp and hydraulic cooling fans are on.
Hydraulic Oil Filter Restriction Switch	521106	31	Filter is restricted and hydraulic cold start is not on.	Amber warning lamp is on.
Left Hand Pitch Position	521122	0	Sensor output is > 4 mm above max calibration point.	Amber warning lamp is on. Smart pitch is disabled.
		13	The sensor needs calibration.	Amber warning lamp is on. Smart pitch is disabled.
		31	Pitch actuator fault: voltage beyond 9–16 V, temp beyond -40–185°F, more than 18 A, backdrive, wrong parameter, or service needed	Amber warning lamp is on. Smart pitch is disabled.
Right Hand Pitch Position	521123	0	Sensor output is > 4 mm above max calibration point.	Amber warning lamp is on. Smart pitch is disabled.
		13	The sensor needs calibration.	Amber warning lamp is on. Smart pitch is disabled.
		31	Pitch actuator fault: voltage beyond 9–16 V, temp beyond -40–185°F, more than 18 A, backdrive, wrong parameter, or service needed	Amber warning lamp is on. Smart pitch is disabled.
Left Motor Speed Sensor	521127	0	Sensor 1 frequency is too high.	Amber warning lamp is on. Motor speed control is open loop.
		5	Sensor 1 open circuit	Amber warning lamp is on. Motor speed control is open loop.
		13	Parameters are corrupt or missing. Load or reset parameters.	Amber warning lamp is on. Motor speed control is open loop.
		31	The frequency difference between the two signals exceeds 5%.	Amber warning lamp is on. Motor speed control is open loop.

TROUBLESHOOTING

Table 19. Machine Fault Codes (Continued)

Parameter Name	SPN	FMI	Fault Conditions	Fault Reactions
Right Motor Speed Sensor	521128	0	Sensor 1 frequency is too high.	Amber warning lamp is on. Motor speed control is open loop.
		5	Sensor 1 open circuit	Amber warning lamp is on. Motor speed control is open loop.
		13	Parameters are corrupt or missing. Load or reset parameters.	Amber warning lamp is on. Motor speed control is open loop.
		31	The frequency difference between the two signals exceeds 5%.	Amber warning lamp is on. Motor speed control is open loop.
Pedal Position 1	521131	0	Sensor output is significantly more than upper calibration point.	Red stop lamp is on. Pump stroke is disabled.
		1	Sensor output is significantly less than lower calibration point.	Red stop lamp is on. Pump stroke is disabled.
		3	Sensor output is > 4.96 V	Red stop lamp is on. Pump stroke is disabled.
		5	Sensor output is < .05 V	Red stop lamp is on. Pump stroke is disabled.
		13	The sensor needs calibration.	Red stop lamp is on. Pump stroke is disabled.
Hydraulic Unloader Valve	521151	31	Open circuit, short circuit, or over temperature	Amber warning lamp is on. Valve is off.
Left Stroke Valve	521152	0	Above normal most severe	Red stop lamp is on. Pump stroke is disabled.
		1	Below normal most severe	Red stop lamp is on. Pump stroke is disabled.
		3	Short circuit	Red stop lamp is on. Pump stroke is disabled.
		5	Open circuit	Red stop lamp is on. Pump stroke is disabled.
		13	Parameters are corrupt or missing. Calibrate or reload parameters.	Red stop lamp is on. Pump stroke is disabled.
		31	Input is out of range.	Red stop lamp is on. Pump stroke is disabled.
Right Stroke Valve	521153	0	Above normal most severe	Red stop lamp is on. Pump stroke is disabled.
		1	Below normal most severe	Red stop lamp is on. Pump stroke is disabled.
		3	Short circuit	Red stop lamp is on. Pump stroke is disabled.
		5	Open circuit	Red stop lamp is on. Pump stroke is disabled.
		13	Parameters are corrupt or missing. Calibrate or reload parameters.	Red stop lamp is on. Pump stroke is disabled.
		31	Input is out of range.	Red stop lamp is on. Pump stroke is disabled.

TROUBLESHOOTING

Table 20. Machine Fault Codes (Continued)

Parameter Name	SPN	FMI	Fault Conditions	Fault Reactions
Pedal Position 2	521156	0	Sensor output is significantly more than upper calibration point.	Amber warning lamp is on. Cruise control is disabled.
		1	Sensor output is significantly less than lower calibration point.	Amber warning lamp is on. Cruise control is disabled.
		3	Sensor output is > 4.96 V	Amber warning lamp is on. Cruise control is disabled.
		5	Sensor output is < .05 V	Amber warning lamp is on. Cruise control is disabled.
		13	The sensor needs calibration.	Amber warning lamp is on. Cruise control is disabled.
		31	The output of both foot pedal sensors does not match.	Amber warning lamp is on. Cruise control is disabled.
Fuses	521198	5	A fuse is blown.	Amber warning lamp is on.
Relays	521199	31	A relay has a fault.	Amber warning lamp is on.
Left Motor Speed Sensor	521211	0	Sensor 2 frequency is too high.	Amber warning lamp is on. Motor speed control is open loop.
		5	Sensor 2 open circuit	Amber warning lamp is on. Motor speed control is open loop.
Right Motor Speed Sensor	521212	0	Sensor 2 frequency is too high.	Amber warning lamp is on. Motor speed control is open loop.
		5	Sensor 2 open circuit	Amber warning lamp is on. Motor speed control is open loop.
Hydraulic Oil Level	521216	0	Oil level is very high, sensor output is < 0.25 V, or open circuit.	Red stop lamp is on. Cruise control is disabled.
		1	Oil level is very low, sensor output is > 4.75 V, or short to power.	Red stop lamp is on. Cruise control is disabled.
		17	Oil level is too low. Add oil to the system.	Amber warning lamp is on. Cruise control is disabled.

TROUBLESHOOTING

Troubleshooting (Ride-On Hydraulic Trowel)		
Symptom	Possible Problem	Solution
Seat switch not functioning.	Other problems?	Check seat function with the electronic service tool.
	Loose wire connections?	Check wiring. Replace as necessary.
	Bad contacts?	Replace seat cushion (contains the switch).
If trowel bounces, rolls concrete, or makes uneven swirls in concrete.	Blades?	Make certain blades are in good condition, not excessively worn. Finish blades should measure no less than 2" (50mm) from the blade bar to the trailing edge, combo blades should measure no less than 3.5" (89 mm). Trailing edge of blade should be straight and parallel to the blade bar.
	Spider?	Check that all blades are set at the same pitch angle as measured at the spider. A field adjustment tool is available for height adjustment of the trowel arms.
	Bent trowel arms?	Check the spider assembly for bent trowel arms. If one of the arms is even slightly bent, replace it immediately.
	Trowel arm bushings?	Check the trowel arm bushings for tightness. This can be done by moving the trowel arms up and down. If there is more than 1/8" (3.2 mm) of travel at the tip of the arm, the bushings should be replaced. All bushings should be replaced at the same time.
	Thrust collar?	Check the flatness of the thrust collar by rotating it on the spider. If it varies by more than 0.02" (0.5 mm) replace the thrust collar.
	Thrust collar bushing? Blade torsion spring hanging below blade?	Check the thrust collar by rocking it on the spider. If it can tilt more than 1/16" (1.6 mm) as measured at the thrust collar O.D., replace the bushing in the thrust collar.
	Thrust bearing worn?	Check the thrust bearing to see that it is spinning freely. Replace if necessary.
	Blade pitch?	Check blades for consistent pitch. Adjust per Maintenance section instructions if necessary.
Machine has a perceptible rolling motion while running.	Spider finger screws?	Adjust per procedure in Maintenance section.
	Yoke?	Check to make sure that both fingers of the yoke press evenly on the wear cap. Replace yoke as necessary.
	Blade pitch?	Check to ensure that each blade is adjusted to have the same pitch as all other blades. Adjust per Maintenance section in manual.

TROUBLESHOOTING

Troubleshooting (Ride-On Hydraulic Trowel) Continued		
Symptom	Possible Problem	Solution
Lights (optional) not working.	Wiring?	Check all electrical connections, including the master on/off switch and check to see if wiring is in good condition with no shorts. Replace as necessary.
	Lights?	Check to see if light bulbs are still good. Replace if broken.
Retardant spray (optional) not working.	Retardant?	Check retardant level in tank. Fill tank as required.
	Wiring?	Check all electrical connections, including the master on/off switch connections. Replace components and wiring as necessary.
	Bad switch?	Check the continuity of the master on/off switch. Replace if broken.
	Bad spray pump?	If pump has a voltage present when the switch is turned on, but does not operate and electrical connections to the pump are good, replace the pump.
	Bad fuse?	Check fuse. Replace fuse if defective.
Steering is unresponsive.	Blade speed out of adjustment?	See section on blade speed adjustment.
	Worn components?	Check for wear of steering bearings and linkage components replace if necessary.
	Pivots?	Check to ensure free movement of hydraulic drive motors.
	Hydraulic pressure?	Check to ensure that hydraulic steering pressure is adequate. See section on checking hydraulic steering pressure.
Operating position is uncomfortable.	Seat adjusted for operator?	Adjust seat with lever located on the front of the seat.
Pitch system not working.	Wiring?	Check and repair wiring and connectors as necessary.
	Actuators?	Check actuator faults with the Whiteman Service Tool (WST).

TROUBLESHOOTING

Troubleshooting (Engine)		
Symptom	Possible Problem	Solution
Difficult to start, fuel is available, but no spark at spark plug.	Spark plug bridging?	Check gap, insulation or replace spark plug.
	Carbon deposit on spark plug?	Clean or replace spark plug.
	Short circuit due to deficient spark plug insulation?	Check spark plug insulation, replace if worn.
	Improper spark plug gap?	Set to proper gap.
	Spark plug is red?	Check transistor ignition unit.
	Spark plug is bluish white?	If insufficient compression, repair or replace engine. If injected air leaking, correct leak. If carburetor jets clogged, clean carburetor.
	No spark present at tip of spark plug?	Check transistor ignition unit and replace if defective. Check voltage cord and replace if cracked or broken. Check spark plug and replace if fouled.
	No oil?	Add oil as required.
	Oil pressure alarm lamp blinks upon starting? (if applicable)	Check automatic shutdown circuit, oil sensor. (if applicable)
Difficult to start, fuel is available, and spark is present at the spark plug.	ON/OFF switch is shorted?	Check switch wiring, replace switch.
	Ignition coil defective?	Replace ignition coil.
	Improper spark gap, points dirty?	Set correct spark gap and clean points.
	Condenser insulation worn or short circuiting?	Replace condenser.
	Spark plug wire broken or short circuiting?	Replace defective spark plug wiring.
Difficult to start, fuel is available, spark is present and compression is normal.	Wrong fuel type?	Flush fuel system, replace with correct type of fuel.
	Water or dust in fuel system?	Flush fuel system.
	Air cleaner dirty?	Replace air cleaner.
Difficult to start, fuel is available, spark is present and compression is low.	Suction/exhaust valve stuck or protruded?	Reseat valves.
	Piston ring and/or cylinder worn?	Replace piston rings and/or piston.
	Cylinder head and/or spark plug not tightened properly?	Torque cylinder head bolts and spark plug.
	Head gasket and/or spark plug gasket damaged?	Replace head and spark plug gaskets.

ELECTRICAL WIRING DIAGRAM

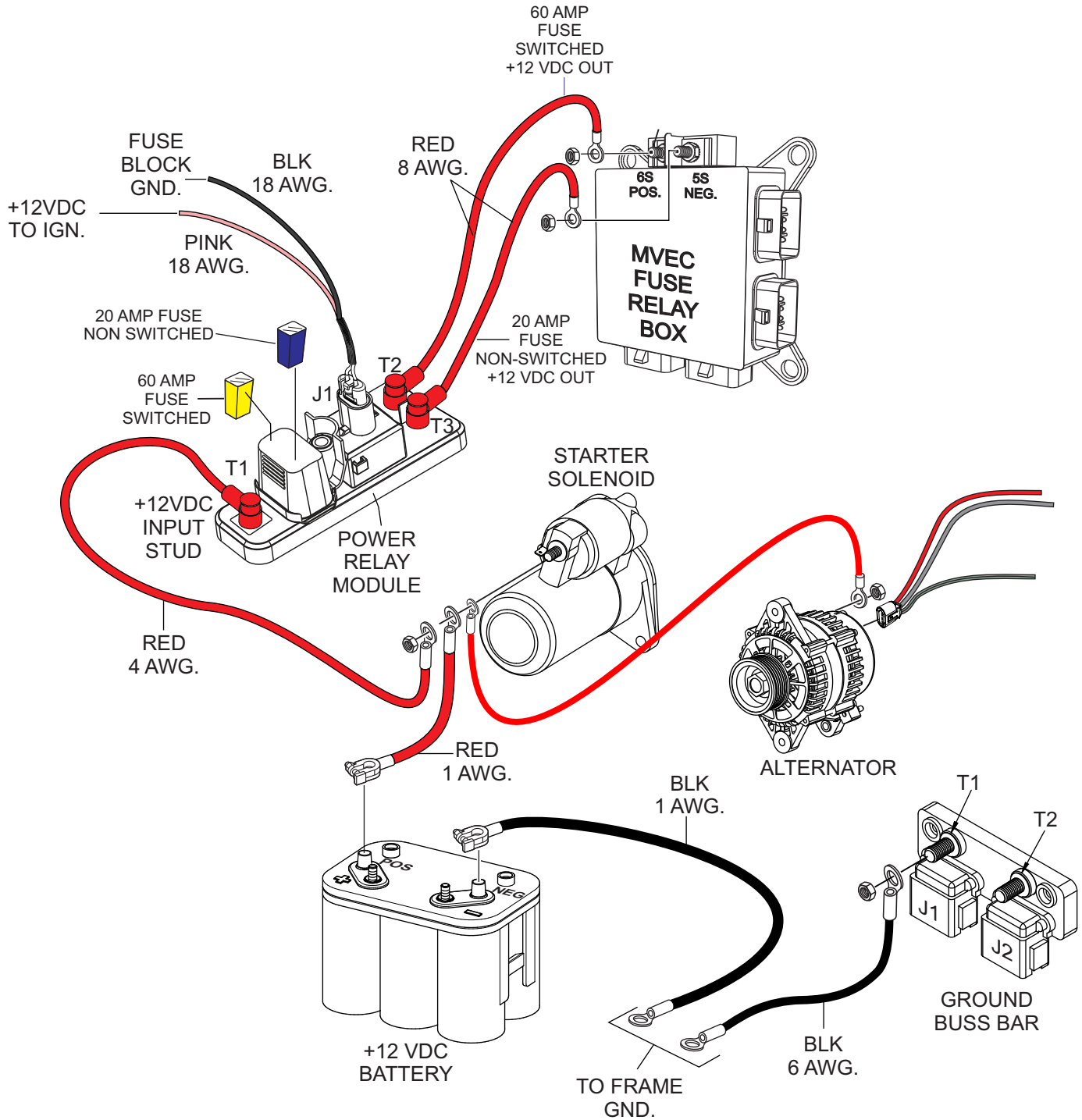

FUSE AND RELAY LOCATOR

MVEC FUSE/RELAY BOX

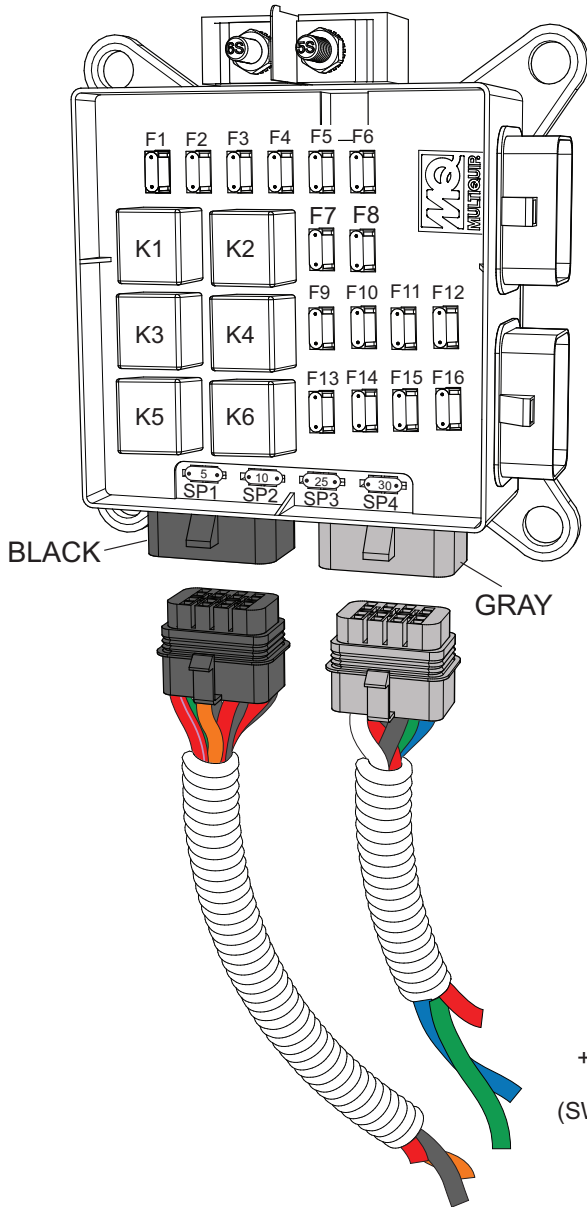

REFERENCE DESIGNATOR	FUNCTION
F1	FUSE, RIGHT-SIDE COOLER, 25 AMP
F2	FUSE, SPARE, 25 AMP
F3	FUSE, SPARE, 10 AMP
F4	FUSE, LEFT-SIDE LIGHTS, 10 AMP
F5	FUSE, RIGHT-SIDE LIGHTS, 10 AMP
F6	FUSE, ACCESSORY, 5 AMP
F7	FUSE, LEFT-SIDE PITCH, 30 AMP
F8	FUSE, LEFT-SIDE COOLER, 25 AMP
F9	FUSE, SEAT SWITCH, 5 AMP
F10	FUSE, SWITCHES, 5 AMP
F11	FUSE, IGNITION SWITCH, 10 AMP
F12	FUSE, 9-PIN OBD CONNECTOR, 10 AMP
F13	FUSE, MCU/I/O MODULE, 20 AMP
F14	FUSE, RIGHT-SIDE PITCH, 30 AMP
F15	FUSE, SPRAY PUMPS, 20 AMPS
F16	FUSE, SPARE, 10 AMP
K1	RELAY, LEFT-SIDE LIGHTS
K2	RELAY, RIGHT-SIDE LIGHTS
K3	RELAY, SPARE
K4	RELAY, LEFT-SIDE COOLER
K5	RELAY, RIGHT-SIDE COOLER
K6	RELAY, SPARE
SP1	FUSE, SPARE, 5 AMP
SP2	FUSE, SPARE, 10 AMP
SP3	FUSE, SPARE, 25 AMP
SP4	FUSE, SPARE, 30 AMP

TYPICAL FUSE/RELAY WIRING CONFIGURATION

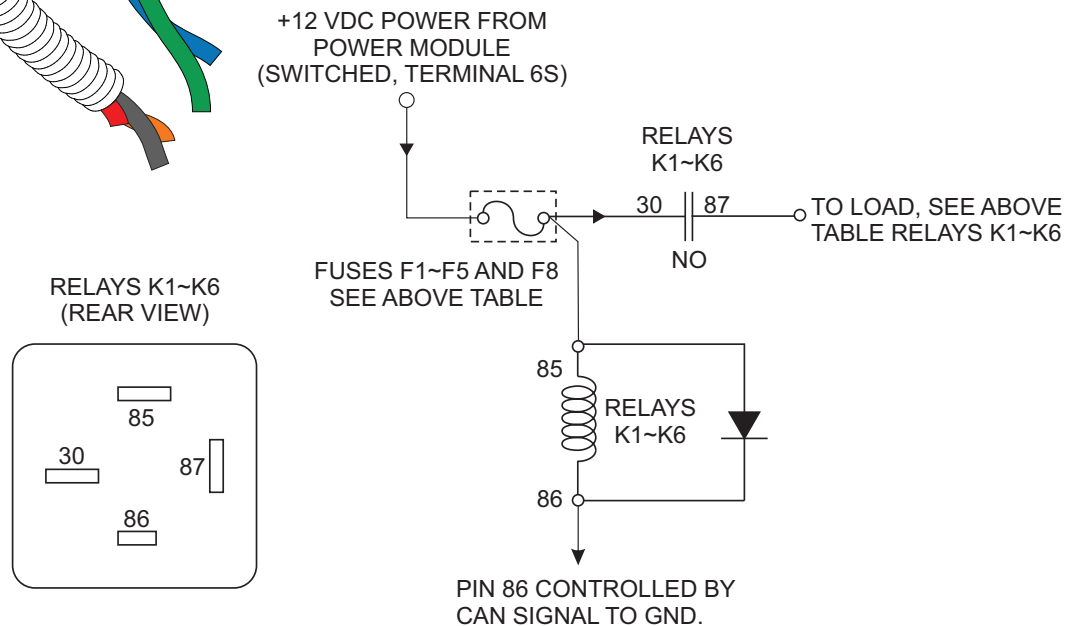

HYDRAULIC COMPONENT LOCATOR

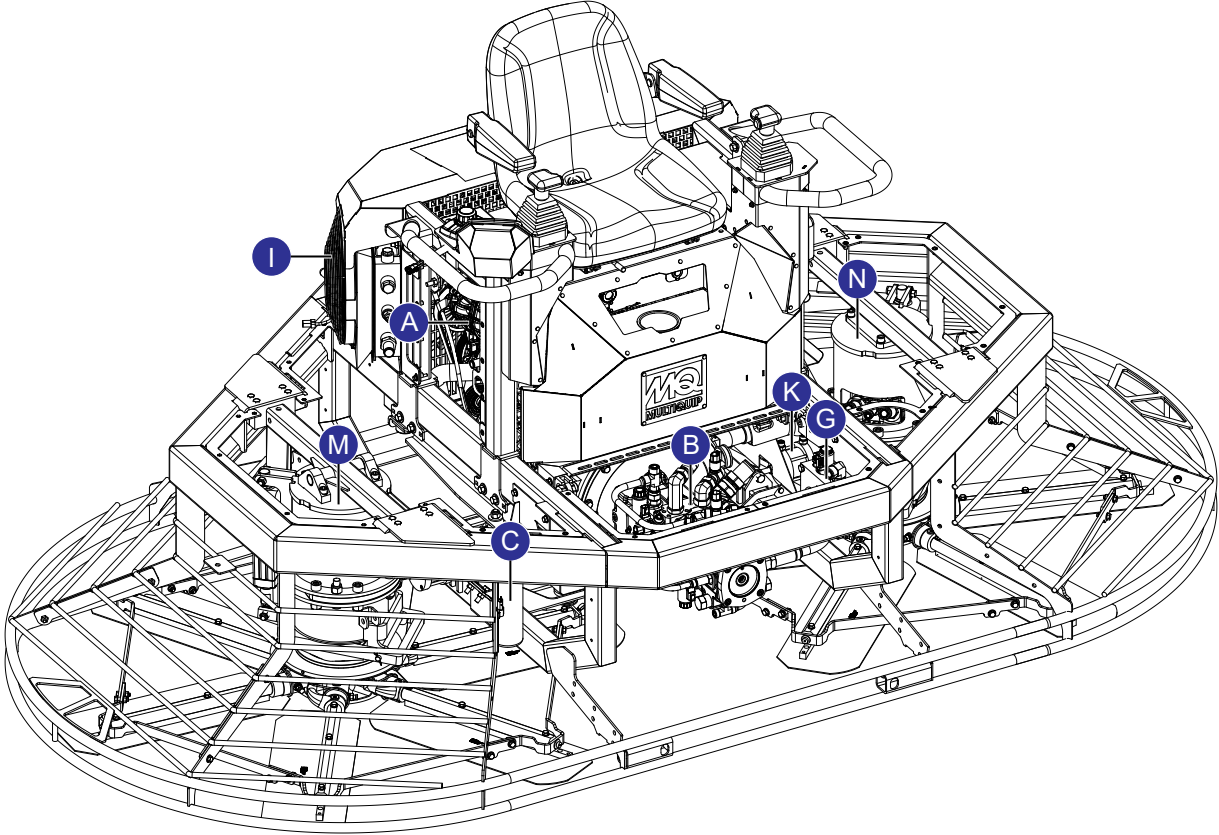
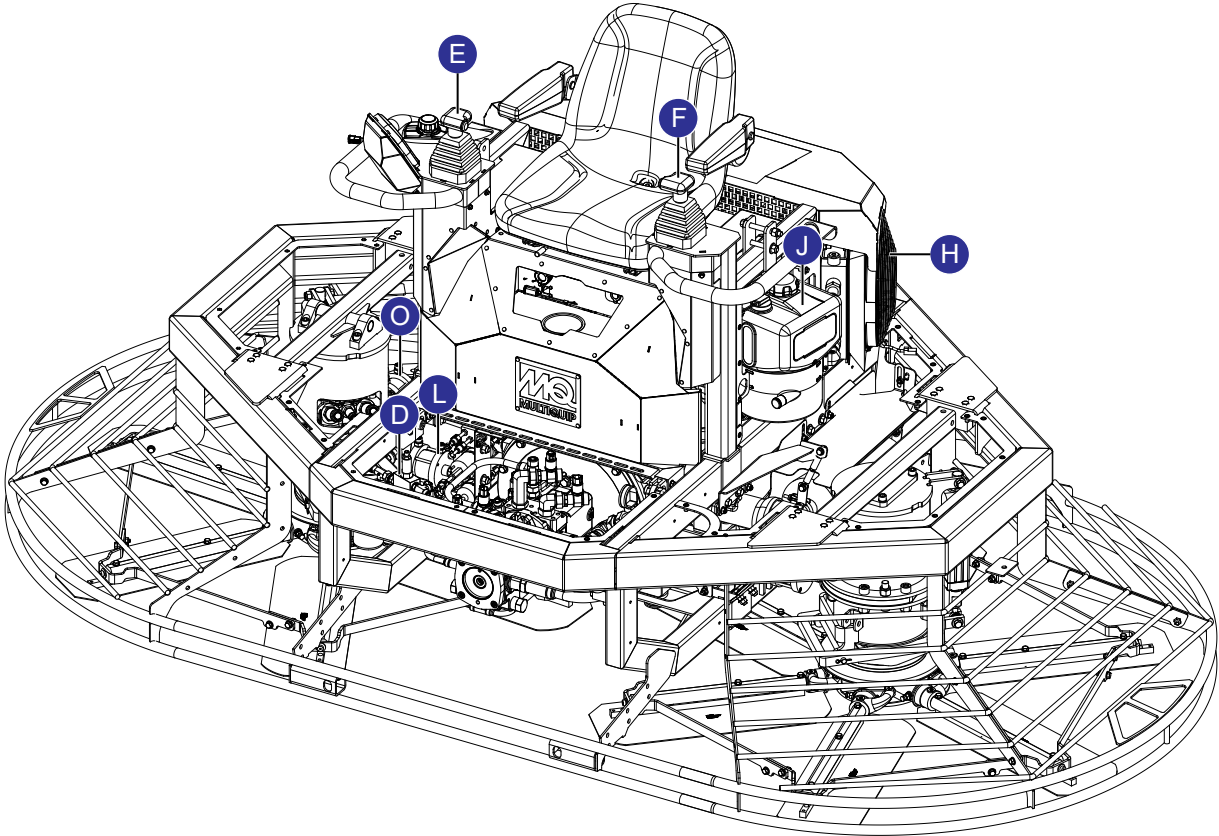

HYDRAULIC SYSTEM DIAGRAM

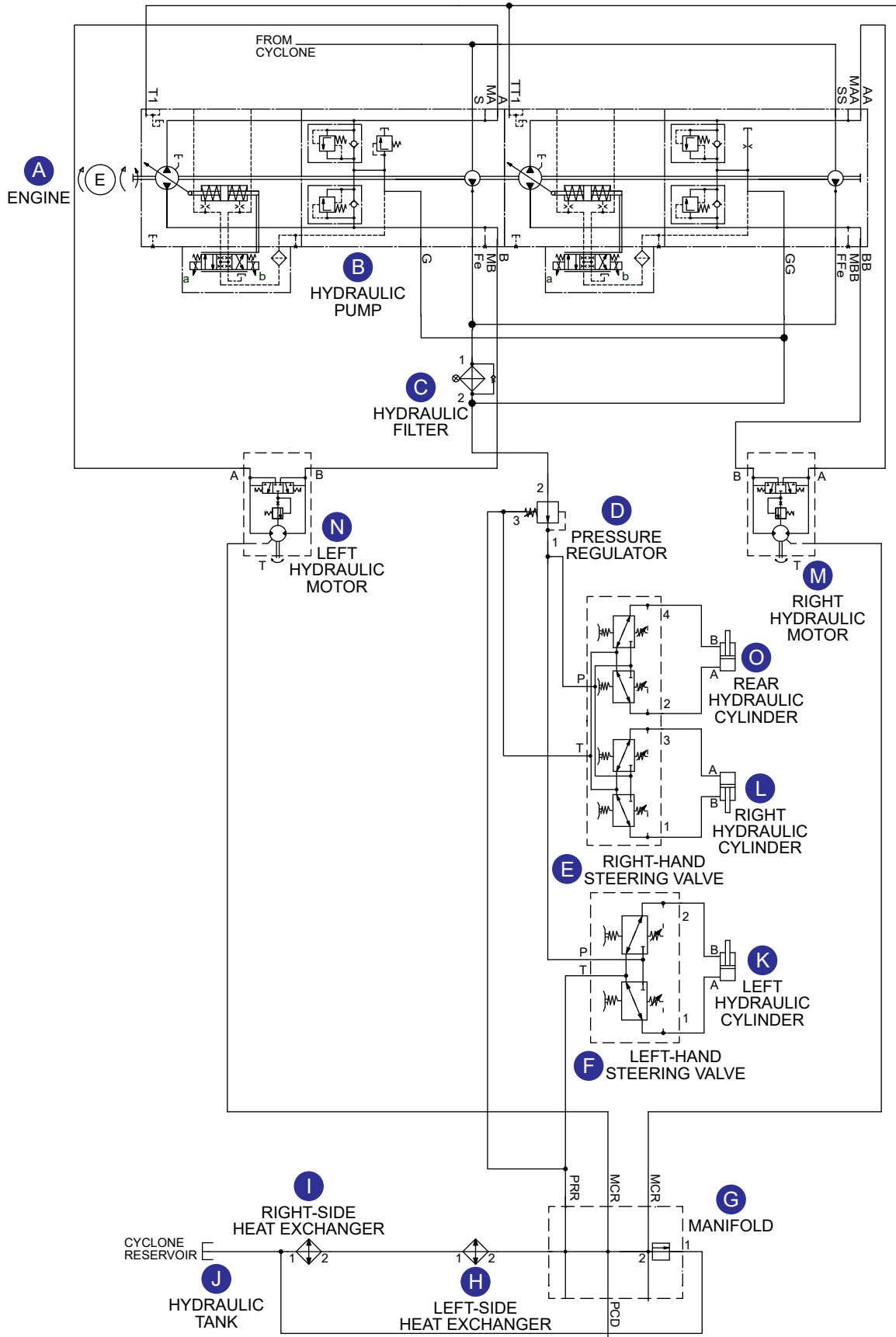

OPERATION MANUAL

HERE'S HOW TO GET HELP

PLEASE HAVE THE MODEL AND SERIAL
NUMBER ON-HAND WHEN CALLING

UNITED STATES

Multiquip Inc.

(310) 537- 3700
6141 Katella Avenue Suite 200
Cypress, CA 90630
E-MAIL: mq@multiquip.com
WEBSITE: www.multiquip.com

CANADA

Multiquip

(450) 625-2244
4110 Industriel Boul.
Laval, Quebec, Canada H7L 6V3
E-MAIL: infocanada@multiquip.com

UNITED KINGDOM

Multiquip (UK) Limited Head Office

0161 339 2223
Unit 2, Northpoint Industrial Estate,
Globe Lane,
Dukinfield, Cheshire SK16 4UJ
E-MAIL: sales@multiquip.co.uk

© COPYRIGHT 2021, MULTIQUIP INC.

Multiquip Inc, the MQ logo are registered trademarks of Multiquip Inc. and may not be used, reproduced, or altered without written permission. All other trademarks are the property of their respective owners and used with permission.

This manual MUST accompany the equipment at all times. This manual is considered a permanent part of the equipment and should remain with the unit if resold.

The information and specifications included in this publication were in effect at the time of approval for printing. Illustrations, descriptions, references and technical data contained in this manual are for guidance only and may not be considered as binding. Multiquip Inc. reserves the right to discontinue or change specifications, design or the information published in this publication at any time without notice and without incurring any obligations.

Your Local Dealer is:



PN: 13415